



# Elver and eel passes

A guide to the design and implementation of passage solutions at weirs, tidal gates and sluices

The Eel Manual— GEHO0211BTMV-E-E

We are The Environment Agency. It's our job to look after your environment and make it **a better place** – for you, and for future generations.

Your environment is the air you breathe, the water you drink and the ground you walk on. Working with business, Government and society as a whole, we are making your environment cleaner and healthier.

The Environment Agency. Out there, making your environment a better place.

**Published by:**

Environment Agency  
Horizon house, Deanery Road  
Bristol BS1 5AH  
Tel: 0117 934 4000  
Email: [enquiries@environment-agency.gov.uk](mailto:enquiries@environment-agency.gov.uk)  
[www.environment-agency.gov.uk](http://www.environment-agency.gov.uk)

© Environment Agency

All rights reserved. This document may be reproduced with prior permission of the Environment Agency.

Further copies of this report are available from our publications catalogue: <http://publications.environment-agency.gov.uk> or our National Customer Contact Centre: T: 08708 506506

E: [enquiries@environment-agency.gov.uk](mailto:enquiries@environment-agency.gov.uk).

# Contents

<b>Contents</b>	<b>iii</b>
<b>1 Introduction</b>	<b>1</b>
<b>2 Prioritising Eel Pass Solutions</b>	<b>3</b>
<b>3 Climbing Substrates</b>	<b>4</b>
3.1 Bristle and brush substrates	4
3.2 Other synthetic substrates	5
<b>4 Gauging Weirs</b>	<b>9</b>
4.1 Introduction	9
4.2 Bristle Board Eel Passes	9
4.3 'Up and Over' Eel Passes	18
<b>5 Non-gauging weirs</b>	<b>26</b>
5.1 Dam wall	26
5.2 Natural falls	26
5.3 Culverts/Irish bridges and fords	26
5.4 Weirs	27
<b>6 Tidal flaps and gates</b>	<b>37</b>
6.1 What are the issues?	40
6.2 Options for fish passage at tidal flaps	44
<b>7 Self-regulating tidal flaps and gates</b>	<b>51</b>
7.1 The Waterman SRT	52
7.2 The Williams SRT	53
7.3 Muted tidal-regulated (MTR) gate, Nehalem Marine.	56
7.4 Variable backflow flap gate (VBFSTM), Juel Tide Gates	58
7.5 Mouse holes, cat flaps and pet doors	59
7.6 Installation of light-weight gates	65
7.7 Counter-balanced flap gates	67
7.8 Automated gates	71
7.9 Siphon passes and piped passes	71
7.10 Revolving doors	74
<b>8 Sluices</b>	<b>75</b>
8.1 In-river structures	75
<b>Appendix</b>	<b>88</b>

<b>Glossary of terms</b>	<b>93</b>
<b>Manufacturers</b>	<b>94</b>



# 1 Introduction

There are around 26,000 obstructions in England and Wales that could prevent eel and elver travelling freely upstream. Of these, about 16,000 are artificial. The obstructions come in a large variety of forms, functions and sizes, and this can make it very hard to identify the best solution for fish passage.



**Figure 1: Duxbury Weir is an obstruction on the River Yarrow.  
(Note: There is now a fish pass at this site to make it easier for fish to travel upstream).**

This Manual is intended to simplify that search by bringing together in one place all the relevant examples, best practice, good ideas and tips from those who have designed and built eel and elver passes. This builds upon previous Environment Agency R&D Technical Reports “Fish Pass Design for Eel and Elver”, W2-070/TR1 and “Manual for the provision of upstream migration facilities for eel and elver”, W2-070/TR2, published in 2004 and attempts to answer all the basic questions about eel passage solutions. These include:

- What is the best solution for eel passage?
- How do I go about making it happen?
- Where do I get the materials?
- Who will build it for me?
- How much will it all cost?

This document is the result of a two-day eel workshop held in October 2009. It is the work of: Jim Gregory, Diane Holland, Scott McKenzie, Dave Hunter, Pete Evoy, Stephen Carter, Michael Clyde, Andy Don, Charles Crundwell, Adrian Fewings and Chris Randall. The section on tidal flap gates and self-regulating tide gates is based on work commissioned by the Environment Agency and produced by David Solomon.

For information on fish passes for other species and on the fish pass approval process, refer to the “Environment Agency [Fish Pass Manual](#): Guidance notes on the legislation, selection and approval of fish passes in England and Wales”, V2.1 (2010).

## 2 Prioritising Eel Pass Solutions

The Eels (England and Wales) Regulations 2009 Statutory Instrument (SI) came into force on 15 January 2010 and supports Council Regulation (EC) No 1100/2007, which requires Member States to develop Eel Management Plans (EMPs) for each river basin district, with the objective of permitting the escapement to the sea of at least 40 % of the historic silver eel biomass.

Under the 2007 Regulation Member States are required to report to the European Commission on the implementation of the EMPs, with the first report to be presented by 30 June 2012.

Part 4 of the SI – Passage of Eels:  
makes 'provisions for the passage of eels through dams and other obstructions' (regulations 12 to 16).

It is therefore essential that we develop accepted criteria, and a standard process, by which barriers may be assessed and prioritised for eel passage and screening.

The eel workshop's 'passes group' formulated the following list of factors to take into consideration when formulating a prioritisation strategy for eel passage solutions. Prioritisation will be led by Head Office.

Parameter	National Dataset or local assessment	WB or site specific	Rank
Upstream Productivity	WFD Data	WB	1
Distance to next barrier	Obstructions Database	Site	1
Available Habitat to next barrier	Obstructions Database	Site	1
Distance from head of tide	Obstructions Database	Site	1
WFD status	WFD Data	WB	1
Altitude	GIS derived	Site	2
Escapement potential	Local input	Catchment	2
passability	Local input	Site	2
Structure Futures	Local input	Site	2
Commercial fishery operation	EMP	Catchment	2
Parasitic status	EMP	Catchment	3
Pesticide status	WFD Data	WB	3
Silver eel escapement compliance	EMP	RBD	3
Geographical location and spread	GIS derived	Catchment	3
Designation (SAC, SSSI)	GIS derived	Site	3
Elver pass present	Local input	Site	3
Ownership (EA)	Local input	Site	3
Predator status	Local input	Catchment	3
Recreational benefit	Local input	Catchment	3
Number of barriers below	Obstructions Database	Site	3
Head drop	Obstructions Database	Site	passability
Upstream/downstream eel population	Local input	Site	passability
Obstruction type	Local input	Site	passability
River Flow conditions	Local input	WB	passability
Hydropower potential	Local input	Site	-

# 3 Climbing Substrates

## 3.1 Bristle and brush substrates

Tufts of bristles of various materials have been used to create substrates for eel passes for many years. Early references record the use of brushes in an eel pass on the Elbe as early as 1964 (O'Leary 1971, and Tesch 1977). These early installations often arranged broom-heads in a suitable pattern. Now, brush mats are made specifically for eel passes and come in a range of materials, dimensions and bristle spacing to suit the site and size of eels. Typical is the range of bristle mats marketed by the French company [Fish-Pass](#).



**Figure 3.1: Bristle substrate with nylon bristles fixed to a polypropylene sheet**

Bristle mats are typically 1,000 mm by 400 mm. They are made from polypropylene with clumps of bristles about 70 mm in length. Each clump comprises about 25 bristles. The spacing of the bristle clumps is varied according to the size of eels that need to pass – with a minimum gap of either 14 or 21 mm. These mats can be used in installations regardless of whether the ramp has a lateral slope.

You can also buy panels with mixed spacing. These have a zone of more closely spaced clumps up the centre and zones of wider spaced clumps to each side. You would generally only use these if there were no lateral slope within the ramp.

You can cut the mats to fit your particular pass, and the current price from Fish-Pass is €131 per 1,000 x 400 mm panel. The price is the same for all bristle spacing.

Many passes in England and Wales have mats that were made to a National Rivers Authority (NRA) specification created in 1994. This specification requires:

- backing boards made of black polypropylene, 9-10 mm thick, 1,000 mm long, and 460 or 1,000 mm wide;
- bristles made of 1 mm gauge green polyester – in clusters to fill 5 mm holes, hand-drawn with stainless steel drawing wire or punch-filled;
- bristle length to be 70 mm proud of board;
- bristle spacing – 5mm holes drilled at 40 mm centres in staggered rows at 20 mm spacing (for eels over 150 mm);



- bristle spacing – 5mm holes drilled at 25 mm centres with 12.5 mm between staggered rows (for elvers and small eels).

Section 7 lists the current contact details for the companies that provided quotes to this specification in 1994. A number of installations using these substrates are detailed by Solomon and Beach (2004), and we describe some of these through this manual.

Legault (1991) investigated the numbers of eels using three pass ramps that had different bristle tuft spacing (7, 14 and 21 mm) at different slopes (15°, 30° and 45°). The results were inconclusive (see table below).

Spacing mm	Slope of ramps		
	15°	30°	45°
21	7.6%	35.5%	52.0%
14	61%	52.3%	38.4%
7	31.4%	12.2%	9.6%
<b>Total</b>	<b>100.0%</b>	<b>100.0%</b>	<b>100.0%</b>

### **Proportion of small eels (mean length 223 mm) using ramps with different bristle substrates at three different slopes.**

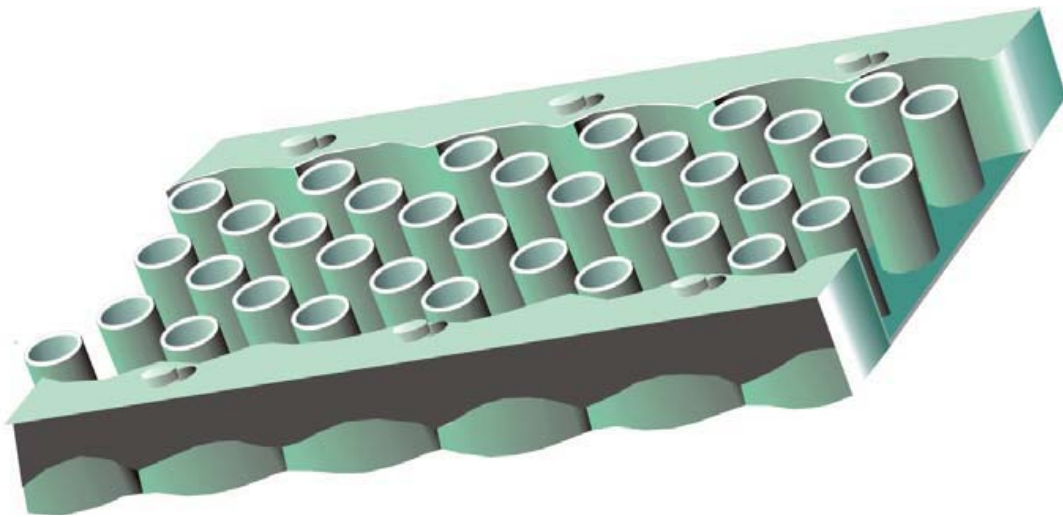
In two of the three ramps, this size-range of eels used the closest substrate spacing (7mm) less than the wider-spaced ones. However, the variation with slope defies simple explanation. Interestingly, the mean length of eels recorded at a fish lift at the same site during the same period was 293 mm. At least one of the passage facilities was clearly size selective. The fast current speeds in the approach to the fish lift may have discouraged smaller eels from entering, or larger eels may have been less inclined to enter the bristle substrate.

## 3.2 Other synthetic substrates

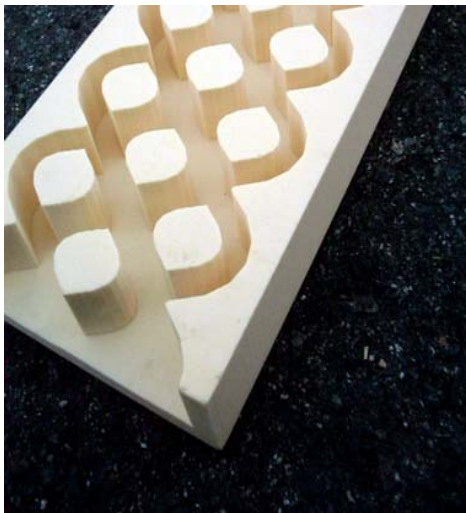
Many other synthetic substrates have been used for eel passes, including:

- sacks sewn together (Tesch, 1977);
- discarded trawl netting (Shotzberger and Strait 2002);
- nylon garden netting and Astroturf (Knights and White 1998);
- artificial vegetation, trade name Cassonia (Eckersley 1982);
- geotextile matting – for example Enkamat 7020 (Dahl 1991), Enkamat 7220 (Wippelhauser 2001), and Tensar (Matthews and others 2001).

Enkamat is described by the manufacturer as ‘a dense three-dimensional permanent erosion prevention mat, made of thick polyamide filaments fused where they cross’. Various thicknesses are available. Types 7020 and 7220 are 20 mm thick. Unfortunately geotextile matting limits the size of eel that can pass through the matrix. Matthews and others mention that the larger ‘bootlace’ eels which passed through their facility late in the season became tangled in the mesh. Dahl (1991) refers to problems with Tensar matting when it was used in pipes: larger eels became jammed and died. Voegtle and Larinier (2000) concluded that Enkamat was very ‘abrasive’, causing eels to lose considerable amounts of mucus. They also found it to be size selective, only allowing eels to pass if they were less than 260 mm. The main use of these substrates maybe at sites where elvers and small eels predominate.



**Figure 3.2: Milieu's Eel-ladder substrate, for eels more than 15 cm long**



**Figure 3.3: Milieu's experimental eel pass substrate, machined from solid polyurethane foam.**

In recent years, some new synthetic substrates have been developed. These are based on round, solid shapes fixed to a flat bed. They are designed for use without a lateral slope, in pumped-supply passes and pass-traps.

One type, used extensively in North America, is called Eel-ladder. It was developed by Milieu Inc of Quebec (see Figure 3.2). The Eel-ladder uses open-topped cylinders 50.8 mm across. These are placed in holes in the substrate bed so that the tops project by 101.6 mm. The substrate comes as a moulded modular channel and only needs a frame to support it. This substrate is designed for eels of 150 to 750 mm, so is best suited to passes some distance up river. This design has been used with great success in passes at Chambly Dam and Beauharnois (both in Quebec), and a number of other sites in Canada (see Solomon and Beach, 2004).

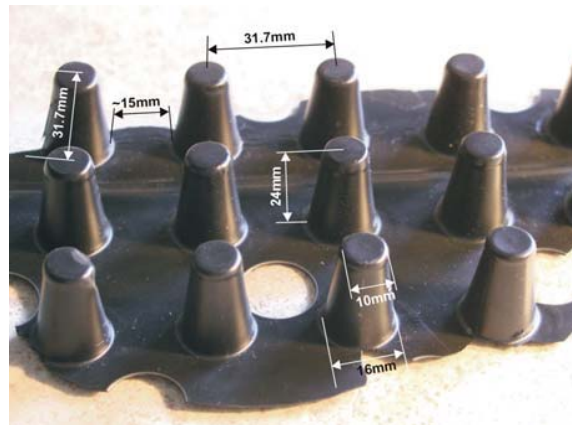
Milieu Inc also manufactures a smaller version of this substrate, for elvers and small eels up to 150 mm long (see Figure 3.3). This has studs 25 mm across within a pre-formed channel 140 mm wide.



**Figure 3.4: Plastic eel pass substrate developed by Fish-Pass in France.**

The French company Fish-Pass has also developed another solid plastic substrate (Figure 3.4). It is made of acrylonitrile butadiene styrene (ABS) and supplied in sheets that are designed to be fixed to sloping weir sills. The shapes are dome-topped cylinders, 30mm in height with 14mm gaps. This shape minimises the build up of debris which could block the pass. The optimal operating water depth within the substrate is 2-12 mm; the optimal slope is up to 35°.

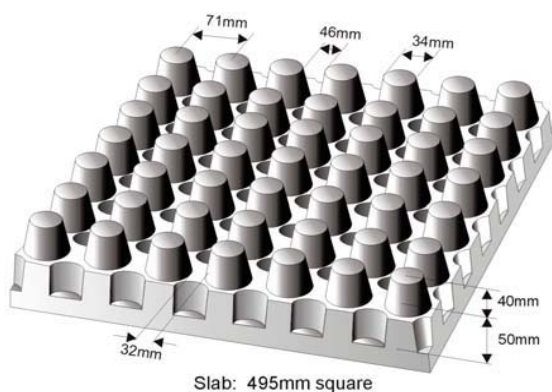
Several eel passes in North America have used a plastic substrate with the trade name of Akwadrain. This is a plastic moulding designed for vertical drainage against underground walls or walls built into banks. Details are shown in Figure 3.5. The main advantages of this material are the very low cost and its physical flexibility. This flexibility could allow it to be draped over weir backs as a temporary installation. The main limitation is its delicate construction: it would need to be regularly replaced in otherwise permanent installations.



**Figure 3.5: Akwadrain plastic substrate**

There have been experiments in France using concrete block substrates, including some originally manufactured for car parks and walkways that allow grass to grow through.

Antoine Legault of Fish Pass has told us that he is experimenting with one such substrate called Pelcar (see Figure 3.6).



**Figure 3.6: Pelcar concrete substrate**

movement on this slope was achieved by swimming rather than crawling, as long as there was an adequate depth of water (10-20mm). At steeper slopes, crawling was more common and smaller eels in particular found ascent more difficult.

When crawling, an eel needs to support its body at several points. This means that different sizes of eel benefit from different stud spacing. The most effective layout of studs was found to be a quincunx, where four objects are set out in a square with a fifth in the centre. This is the pattern formed by the staggered rows of brush bristles described in the specification in Section 6.3.3.

For elvers, bristle substrates and a closely spaced concrete stud substrate worked best. This was because of the level of support provided. For small eels (up to 150 mm in length) these two substrates plus Evergreen gave the best results – provided the depth of water was restricted (less than 20 mm at 15°, 10 mm at 30°, 5 mm at 45°).

Voegtle and Larinier (2000) have examined the effectiveness of several concrete block substrates. Most were made specially but one was a car park block, Evergreen. This is similar to the Pelcar slab. They compared their effectiveness with that of bristle substrates.

Voegtle and Larinier carried out tests at three gradients: 15°, 30° and 45°. For most substrates the shallowest slope worked best, with the highest level of successful passage and the greatest tolerance to variation in headwater level. Most

For larger eels, the brush substrate and a larger concrete stud form were the least selective, particularly on the steeper slopes. All substrates were also tested on a lateral slope of 30° with good results.

Concrete substrates are very strong and most likely to be useful in places where their great inherent strength is an advantage, such as sites subject to severe floods, vandalism or heavy foot-traffic from canoeists or other river users.



# 4 Gauging Weirs

## 4.1 Introduction

Powerful swimmers, including salmon and sea trout, find it easy to pass through many hydrometric gauging structures such as crump-section weirs. However, it is widely accepted that gauging weirs may make it more difficult for eels to migrate upstream. There are two main factors:

1. The smooth nature of the weir surface provides no 'crawling medium'. Juvenile eels need this to stop themselves being washed downstream.
2. The nature of gauging weirs is such that they tend to have a fast-flowing, shallow downstream face. Water speeds often exceed the swimming capabilities of juvenile eels.

Eels and elver have very specific requirements for fish passage, justifying the installation of dedicated facilities. Providing such facilities can be problematic. There is likely to be resistance to any interference with the precision of flow gauging or the installation of any structure which disturbs the smooth flow of water over the weir. The Environment Agency has developed guidance (See Sections 4.2 and 4.3) on the type of eel pass that is acceptable for installation at river flow measurement structures.

There are two types of eel pass that are acceptable for the different types of gauging weir: bristle board passes and 'up and over' pump-fed passes. As a guide, these can be installed at the following categories of gauging structure:

**Crump weirs and rectangular weirs** - bristle board pass

**Compound crump weirs** - use 'up and over' pump-fed passes or bristle board (where the lowest crest is in the centre section).

**Flat v weirs , V shaped broad crested weirs and flumes** - 'up and over' pump-fed pass.

**Non standard V, U shaped weirs and thin plate weirs (V shapes and rectangular)** - 'up and over' pump-fed or bristle board passes.

General design principles for both types of pass are described in Section 4.2 and 4.3.

**Important note.** At the time of writing, installation and maintenance of eel passes is down to local arrangements on a site by site basis.

## 4.2 Bristle Board Eel Passes

### General design principles

1. The base of the board will make a smooth joint with the upstream and downstream slopes of the crump weir.
2. The boards shall run parallel to the wingwall and be mounted so that the end of the bristle touches the wingwall. The bristle tufts are 70mm long and offset at 30mm intervals. The backing boards are 10mm thick – giving a total board thickness of 80mm, from the tip of the bristles to the back of the

board. The outer face of the backing board is set 80mm out from the wingwall.

3. The boards can only be installed on weirs that are wider than 4m in width. The installation of the board has the effect of reducing the flow calculated over a 4m wide weir of between 1.2 to 1.5% at a crump weir. This reduction in flow becomes less on wider weirs.
4. On crump weirs between 2m and 4 m wide, boards with 30mm bristles and spaced at 30mm may be installed. This gives the same % reduction in flow as item 3 above.
5. Boards cannot be installed on weirs narrower than 2m.
6. The board shall extend downstream sufficiently far enough to ensure that the end of the board is always below the lowest downstream water level expected at the site. This would normally be at or beyond where the downstream 1 in 5 slope of the crump weir terminates.
7. The board shall extend sufficiently far enough upstream to at least the point where the upstream slope of the crump meets the river bed. Where possible it is desirable to extend the board upstream as far as possible and if practical extend around the wingwall return where it curves back into the bank. It is important not to impede the stilling well inlet pipe.
8. The board shall extend to the top of the wingwall or above the modular limit of the gauge above the weir crest which ever is the lesser.
9. The outer face of the board will be smooth with no external fixings or fastenings protruding into to the flow of the river.
10. It should be mounted in such a manner that it can be taken off for cleaning if required.
11. Always undertake any detailed design in conjunction with the local Hydrometry Team.

Figure 4.1 shows a **prototype** bristle board Eel Pass. The flow of water over a weir can be modified sufficiently to allow eel and elver passage by bolting bristle boards to the side walls of the weir. These are suitable to be used at flow measurement structures that have vertical sidewalls and that have water running over the full width of the channel .

**Important note.** The example in Figure 4.1 is a **prototype** bristle board eel pass.



**Figure 4.1: Crest section of installed pass**

Vertical bristle boards can be used at flow measurement structures that have vertical sidewalls known as “wingwalls” and that have water running over the full width of the channel. These are predominantly crump type weirs but can also include compound crump weirs, rectangular broad crested weirs, full width rectangular thin plate weirs and non standard structures. See examples of these different weirs below.



**Figure 4.2 Single crump weir**



**Figure 4.3 Compound Crump weir**

In the compound crump example the pass must be on the lowest crest which is on the right hand bank. Alternatively an up and over eel pass could be installed in the left hand crump (see section 4.3)



**Figure 4.4 Rectangular Weir**

Bristle board eel passes are designed to be installed on crump type weirs. The eel pass is constructed of boards that are supplied in 1m long and 0.4m wide sections with bristle tufts 70mm long spaced at 30mm intervals set on a backing board 10mm thick. They are mounted vertically along one side of the crump weir adjacent to the wing wall (Figure 4.1).

### Fixing boards to the wingwall



**Figure 4.5: Bristle board with floor**



**Figure 4.6: Stand-off bracket**

The boards illustrated in Figure 4.1 are 1m long by 40cm wide. The bristle tufts are 70mm long and offset at 30mm intervals. The backing boards are 10mm thick – giving a total board thickness of 80mm, from the tip of the bristles to the back of the board.

Only fix brackets to the wing walls of the weir above the modular range of the flow gauge. No fixings must be put into the weir face. Fit the boards to the wing walls as shown in Figure 4.1. The boards are held in place with stainless steel brackets. (Those shown in Figure 4.6 were produced by local steel fabricators.) The brackets have a stand-off bend which allows the boards to be fixed without crushing the bristles.





**Figure 4.7: Stand-off bracket and spacer with board fixed**

Fix the boards to the brackets using pre-drilled holes and stainless steel bolts. The bolts pass through the bracket and board, and thread into a 70mm spacer nut (Figures 4.7 and 4.8). This nut prevents the bristles becoming crushed.



**Figure 4.8: Bristle board with stainless steel spacer / nut**

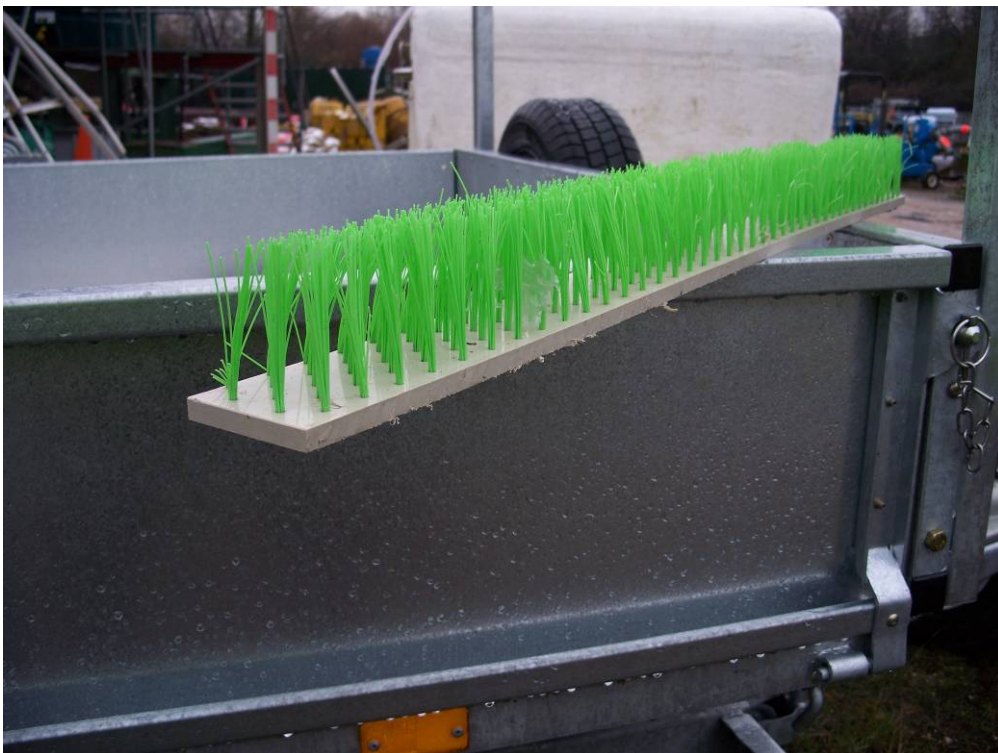
The crest of a crump section weir normally has an upstream slope of 1:2 and a downstream slope of 1:5. The angle at such a crest is  $38^\circ$ , so cut each board at the crest at an angle of  $19^\circ$ . The boards will then fit snugly.

Fit the boards with a floor to prevent an area of fast-moving water forming at the point where elvers would enter the eel pass. This may be achieved by cutting strips of bristle board 70mm wide and fixing them at  $90^\circ$  to the lower edge of the board. The main

bristles should face upward; overlapping bristles should face sideways (see Figures 4.5 and 4.9).



**Figure 4.9: Pre-fabricated stainless steel bracket (showing stand-off)**



**Figure 4.10: Pre-cut floor section**



You may need to remove the bottom two rows of bristles from the main board, in order to allow the bristles on the 70mm strip to mesh with those on the main board. Fix the strip of board in place with stainless steel, self-tapping screws – no additional bonding is required.

When fitting a bristle board pass, make sure you butt all of the boards tightly together to provide a continuous crawling medium. Use enough boards to allow elvers and eels to enter the downstream end of the pass in an area of slower-moving water. The upstream end of the pass must be far enough upstream that eels can swim away from the pass without being swept back over the weir.

You can use ‘thunderbolts’ to fix the brackets to the wing walls (see Figure 4.11).



**Figure 4.11: The ‘thunderbolt’ – an 8mm, self-tapping masonry bolt used to fix brackets to the wingwalls**

‘Thunderbolts’ are self-tapping. They thread into an 8mm hole drilled into masonry without the need for plugs or expanding bolts. This is a great benefit as the holes may be drilled through the brackets. This allows the boards, brackets and spacers to be put together on the bank and then fitted as a unit. We recommend that you use 8mm washers between the bolt heads and brackets.

Where possible, install passes from the bank using cordless or hand tools.

Many crump weirs have curved wing walls upstream and downstream. On these sections, you can bend boards by pulling them in with the brackets. The boards are made from a plastic material and are reasonably flexible. Floors may not be necessary in these areas of slower-moving water.

The installed pass is only 80mm wide and often occupies a very small portion of the weir crest. We know from experience that you may therefore be able to calibrate the weir to allow for the effect of the pass on flow measurement. Where possible, install the pass during periods of lowest flow.

Take care when installing such weir enhancements. In particular, take note of the general risks of working near water, working at height and using power tools. Use generic risk assessments for cleaning and minor site modifications.

**Examples of installation of the prototype bristle board eel pass.**

**Example 1: Frog Mill on the River Hamble (Southern region). NGR SU 5222 1491**



**4.12 Downstream view of pass installation at Frog Mill, River Hamble (NGR: 5222 1491). Note the area of slack water on left for elver and eel to enter pass.**



**Figure 4.13: Installed pass, showing brackets and fixings**





**Figure 4.14: An elver utilising the eel board at Frog Mill**

**Example 2 : Drove Lane on the River Arle, Hampshire .  
NGR: SU 5744 3262**

Showing bristle-board pass on curved wing wall



**Design:** Bristle-board vertical pass. Attached to wing wall of a crump section gauging weir

**Features:** Low tech, maintenance free

**Cost:** Less than £500

**Components:**

1. Bristle boards: pre-fabricated.
2. Fabricated stainless steel brackets.
3. Stand-off spacers to prevent bristle crush.
4. Self-tapping fixing bolts

**Suppliers:**

1. Fish-Pass France ([fishpass@fish-pass.fr](mailto:fishpass@fish-pass.fr))
2. Cottam Brush Ltd ([sales@cottambrush.com](mailto:sales@cottambrush.com)).
3. Fabrication – local engineering company.

**Literature:** Fish pass design for eel and elver (*Anguilla anguilla*), R&D technical report W2-070/TR1, Environment Agency.

**Contact:**

Dave Hunter. Environment Agency, Southern Region.

Richard Iredale. For hydrometric enquiries. Environment Agency, Hydrometry & Telemetry Monitoring, National Monitoring Service, Head Office Operations.

Tel: 0121 7084650

## 4.3 'Up and Over' Eel Passes

**General design principles**

1. Both entrance and exit need to be sited in a manner that is acceptable for eel passage<sup>1</sup> while not compromising the performance of the gauging structure<sup>2</sup>. The lower entrance to the pass should be placed downstream of the end of the gauging weir wing wall. For hydrometric reasons, the eel pass should be fed by water pumped from downstream of the structure wherever possible.
2. The pump should abstract no more than 0.5 litres of flow / second<sup>3</sup>. This assumes that at least half of the 0.5 litre per second is discharged back downstream. Less than half to be discharged upstream of the structure.
3. Such passes can only be installed where the minimum flow of the watercourse exceeds 25 litres/second.
4. The siting of the pass entrance and exit should be near the margins of the stream and not mid – channel.
5. At a site where a high flow rating extends beyond the top of the wing walls, the H&T team will need to consider the impact of the eel pass on that high flow rating.
6. Agreement will need to be achieved between local Fisheries and Hydrometry teams on the design of the eel pass.

7. The Hydrometry team can object to the installation of an eel pass if it considers it has justifiable reasons. Adjudication of disputes will be resolved by the Regional Hydrometry Client Panel.
8. Passes within the walls of a flow gauging weir may be acceptable at some sites if the entire installation is mounted above the level of modular limit for the weir.
9. Where high flows need to be accurately gauged, passes mounted in the weir-channel at high level are not acceptable
10. In rivers where trash and debris could be a significant problem, eel passes mounted within the gauging channel wing wall will be especially vulnerable to damage during high flow events and should be avoided where possible.

#### Notes

1 Near the toe of the obstruction at the d/s; at the u/s where migrants are safe from risk of wash-back

2 Avoids snagging debris or interfering with flow lines

3 Experience has shown that if correctly sited eels will find a very small attraction flow. The nominated flow is sufficient for a bristle pass 200 mm wide that will allow thousands of eels to pass per night. The pump only needs to be operating from dusk till dawn. Key months for use of pass: April-September with some Regional variation

The pictures below show an example of a design for an 'Up and Over ' eel pass at **Bags Mill gauging weir, River Piddle (Wessex South)**. It is a pre-fabricated crawling gutter elver friendly substrate with a pumped flow over it. Detailed plans and original photos from Andy Don, Environment Agency.







Two types of 'Up and Over' Eel Passes are acceptable:

1. Within the area bounded by the gauging structure's wing walls.
2. Where the eel pass is designed to be outside the confines of the structure. This is necessary at sites such as flumes and some weirs with sloping side walls.

Up and Over Eel Passes are suitable to be used at Hydrometric flow gauges where the water does not permanently run across the full width of the weir. These sites are predominantly Flat V weirs, V shaped broad crested weirs, non standard V or U shaped weirs, contracted thin plate weirs (V shapes and rectangular), flumes, or an alternative approach at compound crump weirs with lowest crest in the centre section.

### **Structures suited to up and over type passes**

Examples 1 to 3 below could have eel passes mounted within the confines of the wingwall. Example 4 could have a bristle board pass attached to buttress end of concrete support wall or up and over it.

Examples 5 and 6 would have to have eel passes outside the structure due to sloping wingwalls.



**1. Flat V weir**



**2. V Shaped broad crested weir**



**3. Compound crump. Central low section.**



**4. Contracted thin plate weir**



**5. Flume**



**6. Non standard shaped structures**



**Example of installation of the ‘up and over’ pump-fed eel pass. Bossington – River Test (Southern). NGR: SU 3340 3133.**

**Design:** Fabricated sectional UPVC drainage channel – pumped pass, with bristle-board substrate crawling medium and a 12v solar-powered pump. Water is pumped from the tail water level back to the head of the pass where it descends by gravity.



**Figures 4.15 and 4.16: Crawling gutter of fabricated steel with bristle medium installed and lower lids fitted.**

**(Rule 12v bilge pump and pipe work can be seen in top right.)**

**Note. Hydrometric perspective.** Figs 4.15 and 4.16 are for illustration purposes only. The above eel pass and pump arrangement impact on the flow measurement performance of the structure. The gutter should be located higher up the wing wall beyond the modular range of the structure and the bilge pump pipe should be located outside the flow measurement structure.



**Figure 4.17: UPVC sectional channel**





**Figure 4.18: Crawling gutter under construction. These curved wing walls are found on many gauging structures. (Note the layer of fast-moving water on the downstream weir face and the clean, debris-free surface. Elvers and eels would be unable to swim through this structure.)**



**Figure 4.19: Gutter pass materials and bristle mat substrate being assembled on site.**

The pass is made up of light-weight materials that can be easily transported to the site. The gutter sections lock together to form a continuous channel. The bristle-board sections are inverted when fitted into the channel, so that the backing board forms the lid.



**Figure 4.20: UPVC sectional drainage channel, fixed to side wall. (Hole for pumped water supply at near end, with pump tubing ready for fitting.)**

The pass uses solar energy as well as mains and the control box has a timer to conserve power. The timer allows the pass to run at night during periods of peak migration. Energy generated from solar panels is stored in 12v deep cycle, leisure batteries during daylight hours and used to run the pump at night.



Several types of pump have been tried at a number of sites including the rule bilge pump 12v (500gph) pictured. The rule pumps have been robust and reliable. It is important that the pump does not require more energy than the solar panel can provide.

**Features:** Low tech, low cost and low maintenance. Readily available components. Easily fitted with catch box. Monitoring has shown that pass works well.





**Cost:** Less than £1,500

**Components:**

1. Bristle boards: pre-fabricated.
2. UPVC drainage channel used for block paving drainage. Supplied with lid.
3. 10cm x 5 cm FSC-certified wooden plank bolted to side wall. UPVC channel fixed to this plank.
4. 12v rule submersible pump, with 2.5cm internal outlet. Delivers 2000 litres per hour, at 1.5m head differential.
5. Suitable hosing and wiring.
6. Power supply, through transformer and timer (run at night).
7. Alternative power: solar panel with controller.
8. Suitable sealants and adhesives (as used in aquariums).

**Suppliers:**

1. Fish-Pass France ([fishpass@fish-pass.fr](mailto:fishpass@fish-pass.fr)).
2. tam Brush Ltd ([sales@cottambrush.com](mailto:sales@cottambrush.com)).
3. Local builders merchants for drainage channel.
4. Fabrication – local engineering company.
5. Qualified electrician
6. Sealant supplied by aquatic suppliers.

**Contacts:**

Contact for design type is Andy Don, Environment Agency.

Contact point for pass approvals is Greg Armstrong, Environment Agency

Contact for hydrometric enquiries is Richard Iredale, Environment Agency, Hydrometry & Telemetry Monitoring, National Monitoring Service, Head Office Operations.

Tel: 0121 7084650

**References for constraints at gauging stations:**

Environment Agency (2004). Manual for Provision of Upstream Migration Facilities for Eel and Elver – Science Report SC020075/SR2, P50 – 51

# 5 Non-gauging weirs

## 5.1 Dam wall

These are found where large volumes of water are being impounded, for example for drinking water supply. They are mostly associated with large structures, normally at the head of catchments. They are often impassable without a special fish lift.

Refer to Fish Pass Design for Eel and Elver, Section 3.4 (Solomon and Beach, 2004).

## 5.2 Natural falls

In the past, we have not considered improving fish passage over and around natural obstructions. However, the growing interest in hydropower generation may lead to developers looking at these sites again.

## 5.3 Culverts/Irish bridges and fords

These can create problems with blockage and perching and interrupt gravel movement. Fast-moving water can prevent fish and eel migration. Other problems can be caused by long culvert lengths, steep gradients and smooth sides.

The example below is in the Hafren forest, Wales, on the River Severn.



For further details, see the SEPA/Forestry Commission R&D document, Culverts and crossings

Another example is on the River Liza in the Lake District. Culverts in forest were identified as limiting salmonid migration and preventing gravel movement downstream. The problem was solved by installing a box-section culvert.

We recommend addressing the problem at the consent/planning stage for new applications. There is then an opportunity to push for a design that prevents scour and which provides a ramp/substrate for eel passage at the entrance. We should also check that the nature of the culvert and base eases eel passage.

## 5.4 Weirs

The large diversity in form, size, function and location of weirs means that any eel passage solution is going to be site-specific, requiring individual technical design and consideration.

### **Example 1: Crosthwaite Dam**

**River/catchment:** River Gilpin, Lake District

**NGR:** SD4386691012

**Type of obstruction:** Stone-pitched mill weir

**Issues:** Grade 2 listed structure. Old corn mill has been on site for more than 350 years. Salmon and sea trout migration are impeded at this weir. Gravels upstream are under-utilised. There have been previous attempts to improve fish passage – see photograph. For example, concrete pillows have been built onto the weir apron in an attempt to form a deeper channel. This has been largely ineffective.



**Design solution:** The original design solution (illustrated) was for a single section Larinier fish pass to improve salmonid access. This design was subsequently altered to include an additional notch alongside the salmonid pass. This provides passage for eels. The notch will be lined with bristle board on one side and pelcar studs on the other. The eel pass will then be suitable for eel of different age classes.

**Cost:** Approximately £19,000 in 2009

**Contact:** Environment Agency, North West Region, North Area. Penrith office.



**Eel pass materials:** The bristle board used in the eel notch, as illustrated in the picture.

**Example 2: Blackweir Fish Pass**

**River/catchment:** River Taff, South Wales

**NGR:** ST 1707 7805

**Type of obstruction:** Concrete abstraction weir

**Issues:** The weir is the main abstraction supply for Cardiff docks. It has a large 30-metre wide sill, with an apron 15 m long and a 2.5 metre head drop. Fish passage is required for migratory salmonids and eels.

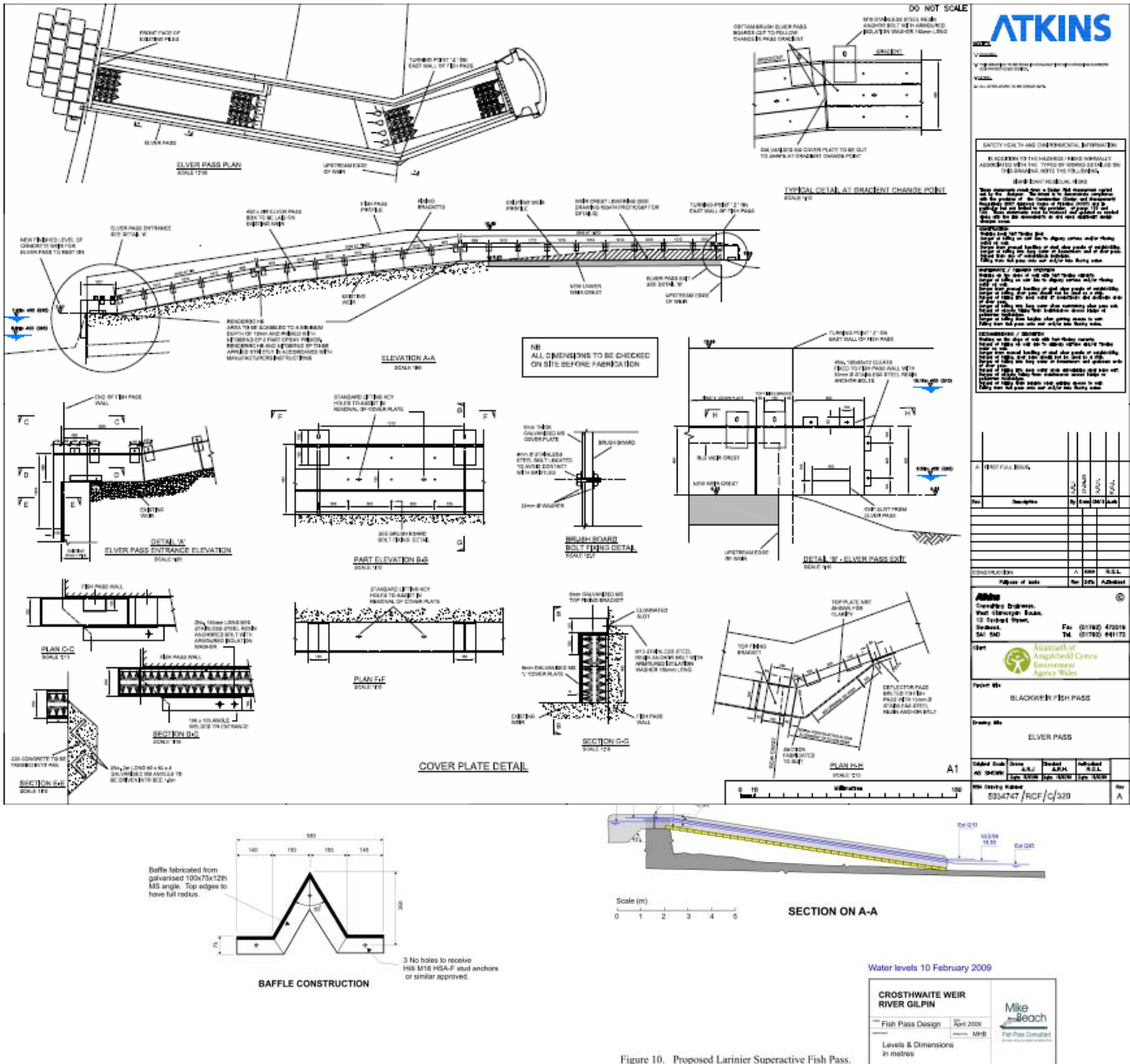


Figure 10. Proposed Larinier Superactive Fish Pass.

**Design solution.** The design solution illustrated is a Larinier fish pass for salmonids with a bristle board bolted on for elvers.

**Cost:** Approximately £19,000 in 2009.

**Contact:** Mike Clyde, Environment Agency Wales, South East Region, Cardiff office.  
Phone 02920 245224.



**Example 3: Head weir**

**River catchment:** River Mole, Taw catchment

**NGR:** SS 6656 1850

**Type of obstruction:** Concrete abstraction weir for former mill, now use as a fish farm.

**Original design solution:** Larinier fish pass with adjacent eel pass.

**Cost:** £250,000 (total includes both passes/designs etc).

**Contact:** Kelvin Broad, Environment Agency, South West Region, Devon area.  
Exminster office. Phone 01392 316032.





#### **Example 4: Bude, Devon**

**River/catchment:** Lower River Neet

**NGR:** SS2070506479

**Type of obstruction:** Adjustable, tidal, amenity weir

**Issues:** An existing weir on the river was due to be removed. However, the local council was concerned that water levels upstream would drop significantly during the summer months. The river is used by canoeists and is popular with holiday-makers. An adjustable weir was installed to ensure water levels remain high during the summer months. However, when the weir is raised during the spring/summer months, it becomes almost impossible for eels and elvers to move upstream. The summer is the main period for elver migration.

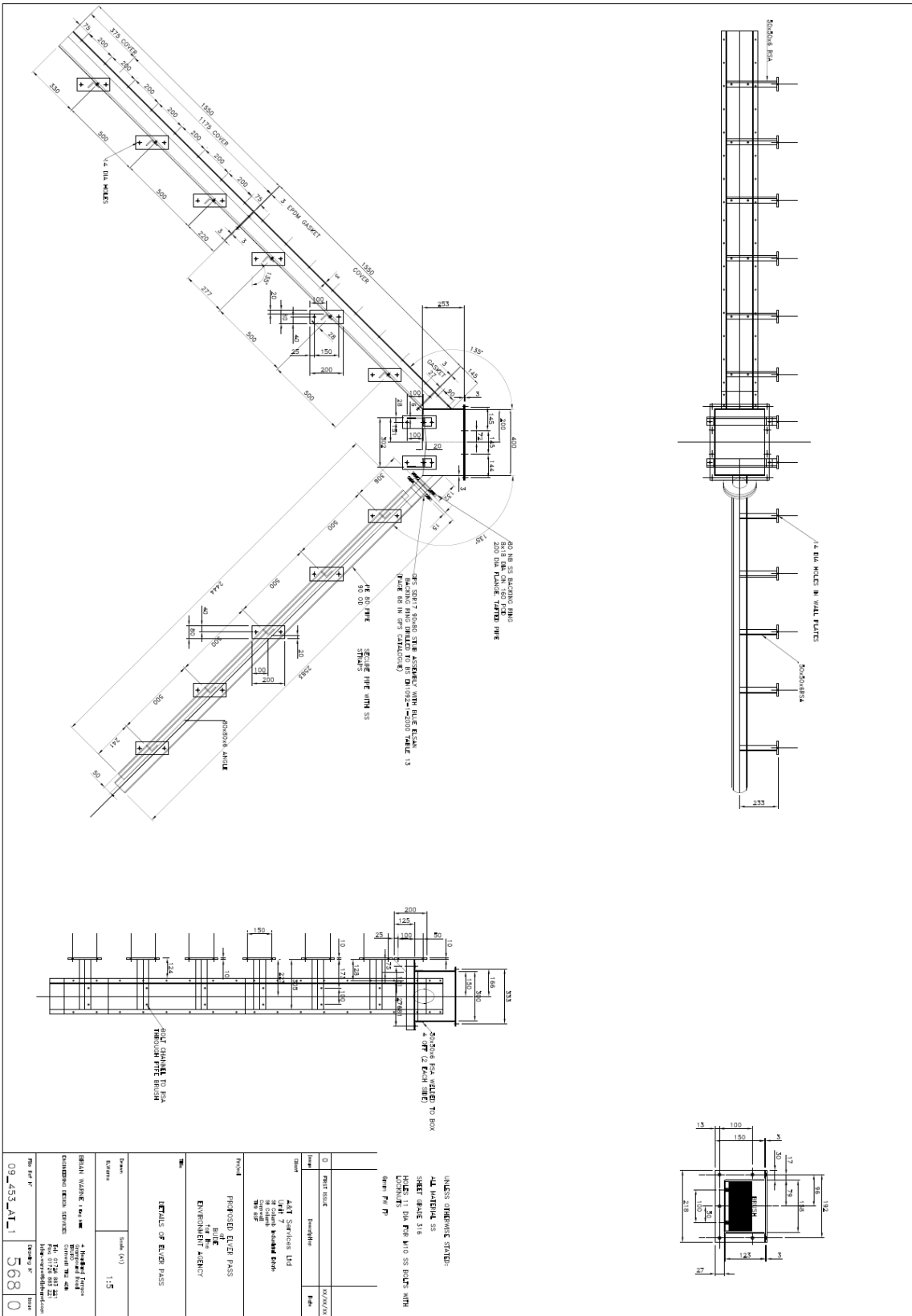


**Design solution:** We attached a boxed-in metal ramp to the concrete wall, and installed a pump to provide water to the brush substrate inside. A camera was also installed as part of the design. Eels and elvers have been monitored using the pass. The operation of the weir meant that the pass had to be 350mm above the existing structure.

**Cost:** £6,750

**Contact:** Kelvin Broad, Environment Agency, South West Region, Devon and Cornwall area. Phone 01208 265012.





UNLESS OTHERWISE SPECIFIED:  
 ALL MATERIALS SS  
 SHEET GRADE 316  
 HOLE 11 DIA FOR 1/2" SS BOLTS WITH  
 LOCKWASHERS  
 (SEE P&ID P1)

ITEM	DESCRIPTION	QUANTITY
01	FRONT BRACKET	2
02	FRONT BRACKET	2
03	FRONT BRACKET	2
04	FRONT BRACKET	2
05	FRONT BRACKET	2
06	FRONT BRACKET	2
07	FRONT BRACKET	2
08	FRONT BRACKET	2
09	FRONT BRACKET	2
10	FRONT BRACKET	2
11	FRONT BRACKET	2
12	FRONT BRACKET	2
13	FRONT BRACKET	2
14	FRONT BRACKET	2
15	FRONT BRACKET	2
16	FRONT BRACKET	2
17	FRONT BRACKET	2
18	FRONT BRACKET	2
19	FRONT BRACKET	2
20	FRONT BRACKET	2
21	FRONT BRACKET	2
22	FRONT BRACKET	2
23	FRONT BRACKET	2
24	FRONT BRACKET	2
25	FRONT BRACKET	2
26	FRONT BRACKET	2
27	FRONT BRACKET	2
28	FRONT BRACKET	2
29	FRONT BRACKET	2
30	FRONT BRACKET	2
31	FRONT BRACKET	2
32	FRONT BRACKET	2
33	FRONT BRACKET	2
34	FRONT BRACKET	2
35	FRONT BRACKET	2
36	FRONT BRACKET	2
37	FRONT BRACKET	2
38	FRONT BRACKET	2
39	FRONT BRACKET	2
40	FRONT BRACKET	2
41	FRONT BRACKET	2
42	FRONT BRACKET	2
43	FRONT BRACKET	2
44	FRONT BRACKET	2
45	FRONT BRACKET	2
46	FRONT BRACKET	2
47	FRONT BRACKET	2
48	FRONT BRACKET	2
49	FRONT BRACKET	2
50	FRONT BRACKET	2
51	FRONT BRACKET	2
52	FRONT BRACKET	2
53	FRONT BRACKET	2
54	FRONT BRACKET	2
55	FRONT BRACKET	2
56	FRONT BRACKET	2
57	FRONT BRACKET	2
58	FRONT BRACKET	2
59	FRONT BRACKET	2
60	FRONT BRACKET	2
61	FRONT BRACKET	2
62	FRONT BRACKET	2
63	FRONT BRACKET	2
64	FRONT BRACKET	2
65	FRONT BRACKET	2
66	FRONT BRACKET	2
67	FRONT BRACKET	2
68	FRONT BRACKET	2
69	FRONT BRACKET	2
70	FRONT BRACKET	2
71	FRONT BRACKET	2
72	FRONT BRACKET	2
73	FRONT BRACKET	2
74	FRONT BRACKET	2
75	FRONT BRACKET	2
76	FRONT BRACKET	2
77	FRONT BRACKET	2
78	FRONT BRACKET	2
79	FRONT BRACKET	2
80	FRONT BRACKET	2
81	FRONT BRACKET	2
82	FRONT BRACKET	2
83	FRONT BRACKET	2
84	FRONT BRACKET	2
85	FRONT BRACKET	2
86	FRONT BRACKET	2
87	FRONT BRACKET	2
88	FRONT BRACKET	2
89	FRONT BRACKET	2
90	FRONT BRACKET	2
91	FRONT BRACKET	2
92	FRONT BRACKET	2
93	FRONT BRACKET	2
94	FRONT BRACKET	2
95	FRONT BRACKET	2
96	FRONT BRACKET	2
97	FRONT BRACKET	2
98	FRONT BRACKET	2
99	FRONT BRACKET	2
100	FRONT BRACKET	2

FRONT  
 PROPOSED ELVER PASS  
 BILL OF MATERIALS  
 ENVIRONMENTAL AGENCY

REVISIONS OF ELVER PASS

NO.	DATE	DESCRIPTION
1	11/25	ISSUED FOR PERMIT

DR: [Name]  
 CHECKED: [Name]  
 DESIGNED: [Name]  
 DRAWING NO: [Number]  
 SHEET NO: [Number]  
 PROJECT NO: [Number]

09\_453\_AT\_1 588 0

**Example 5: Stapleford Mill Weir**

**River/catchment:** River Gowy, Mersey catchment

**NGR:** SJ 48218 64790

**Type of obstruction:** Steep concrete weir

**Issue:** Steep, fast-flowing water, a concrete apron



**Eel pass at Stapleford Mill weir, on the River Gowy: under construction and completed.**

**Design solution:** A pre-fabricated eel gutter was installed on both sides of the weir. This was lined with a brush substrate. This allows a constant flow of water through the gutter– encouraging eel movement. The pass was easily installed.

**Cost:** £3,000

**Contact:** Environment Agency, North West Region, South area

## Example 6: Botley Mill

**River/catchment:** River Hamble, Southampton

**NGR:** SU 5156 1316

**Issue:** Milling has taken place on this site for many years. Parts of the existing building date back to 1536. The site retains a large head of water of more than three metres. The large fall of water hampered the upstream migration of all fish, which could only enter the upper catchment at times of very high flow or high tide.



**Design solution:** A rock ramp was installed in a natural channel of the river. This diverts the water around the obstruction at a flow and level which eels and elvers can use to ascend. The unusual feature of this innovative German design is the use of a regular pattern of upstanding rocks, nearly one metre high, embedded in the pass. This arrangement ensures that the water velocities in the pass are not too high. It also allows fish in the pass to retreat downstream without becoming stranded if the water levels upstream should fall. The pass is 28m long with a 1:22 slope. As it will operate with flows as low as 50 l/sec, the pass works for more than 75% of the year. The pass has opened up 15km of chalk stream habitat upstream of the mill.

**Cost:** £70,000 (2009)

**Contact:** Hannah Wright, Environment Agency, Southern Region, Colvedene Court.  
Phone 01962 764952.



## Example 7: Dursley

**River/catchment:** River Cam

**Issue:** This section of the Cam had previously been in a culvert through an industrial site. When the site came up for redevelopment as housing in 2007, the developers were persuaded to remove the culverts and return the river to an open channel.

**Design solution:** As this section had a large change in gradient, six rock ramps were installed – each with a three-metre drop. The rocks were tipped randomly into the prepared channel rather than being placed precisely.

**Contact:** Charles Crundwell, Environment Agency, Midlands Region, West area. Phone 01684 864374.



# 6 Tidal flaps and gates

## Definitions

Many terms describe structures that allow water to flow seawards by gravity, but not landwards. These terms include tidal flaps, tidal gates, tide gates, flap gates, flap valves and tidal sluices. In this report, 'tidal flap' describes a top-hinged flap, and 'tidal door' a side-hung flap. 'Tidal sluice' describes a structure where gates are lifted or lowered according to the relative levels of water on each side, under either manual or automatic control.

There are of course sites where these structures are located away from tidal influence. Here they are used to isolate the area to be drained from high river levels in the channel to which they drain. The issues for eel passage are similar to those in tidal water.

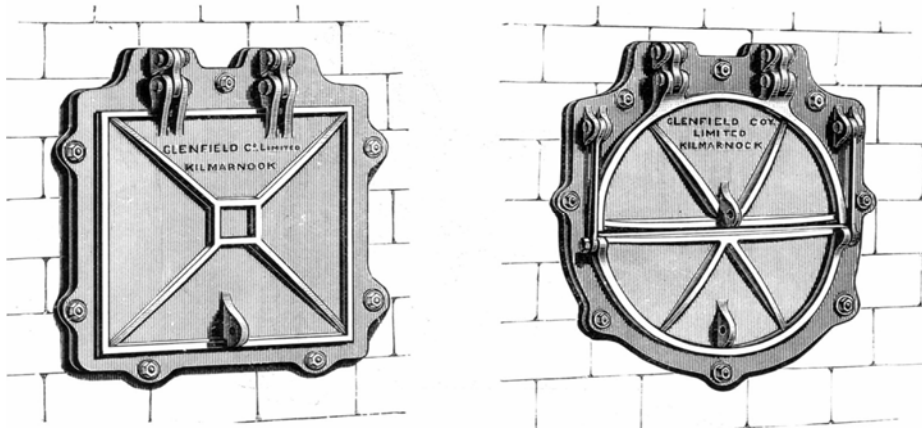
The term 'level equalisation' refers to making the water levels each side of the tidal device the same. There is then no tendency for water to flow in either direction. With tidal flaps, eels can only pass for short periods when levels equalise. This window of opportunity may last for just minutes. Typically, level equalisation will occur twice in each 12-hour tidal cycle – once on the ebbing tide, and once on the flood.

The design of tidal flaps allows run-off to flow seawards when the landward water level is higher than the tide level. But it prevents landward flow of tidal water. Their use has allowed the development of large areas of very productive farm land in areas that were previously flooded by the tide, or were at least poorly drained. Large areas of England and Wales lie below the high-tide level. Much is drained by the use of tidal flaps, tidal doors, tidal sluices or by pumping.

Tidal flaps range greatly in size: from tens of centimetres to several metres in width and depth. They are generally rectangular or circular in shape (see Figure 6.1). Being top-hinged, they tend to close under their own weight. The seating face may be sloped back towards the top to encourage positive seating.

For hundreds of years, tidal flaps were made of wood. Larger installations were reinforced with iron straps. From Victorian times onwards, cast iron was commonly used for small and medium-sized gates. It is still much-used. However a wider range of materials is increasingly common, including stainless steel, cast aluminium, high-density polyethylene (HDPE), co-plastix and other plastic materials. Many flaps are fabricated rather than cast, especially where non-standard sizes or designs are required.





**Figure 7.1. Drawings of cast iron tidal flaps from a 1910 catalogue from Glenfield and Kennedy of Kilmarnock. Note the double hinge link arrangement that allows self-seating of the flap, the lifting eyes, and the split flap arrangement of the circular flap.**

The size of the flap – or more precisely the dimensions of the culvert that the flap controls – is determined by the highest flow that may need to pass through the culvert. This may be the flood flow that follows heavy rain. However, even greater capacity may be needed if the culvert has to drain flooding caused by overtopping of the barrier by storms or exceptional tides (Thorn, 1959). This generally means that the flap nearly always lets through a very small fraction of its maximum capacity –the flap will be open just a crack even at low tide.

Generally, fabricated wooden flaps and frames were imperfect seals. They allowed some landward flow when outside water levels were higher than the levels landwards of the structure. Thorn (1959) described the construction of large wooden flaps: ‘On the larger outfalls they usually comprise an outer skin of vertical timber, felt, and an inner skin of horizontal timber, the whole strengthened by mild steel angle or channel bracing with steel suspensions.’



**Figure 6.2 shows a large wooden flap being removed from a site in Washington State, US. It is clear that in this condition the seal would have been far from perfect – even though the gate was still effective at minimising back-flow when closed.**

Cast-iron flaps and surrounds fitted better, but still often provided an imperfect seal. The latest generation of flaps have purpose-ground seating faces and neoprene seals. When closed, they are effectively waterproof.



**Figure 6.3: The estuary of the River Lymington in Hampshire. These tidal doors are in an open position. The tide has started to flood. The picture shows noticeable landward flow through the structure (towards the right of the picture). A few minutes later, as the landward flow increased, the doors slammed shut.**



**Figure 6.4: Round top hinged tidal flap gate**

Tidal doors, often referred to as pointing doors, tend to be larger than tidal flaps. Generally of wooden construction, they look very like lock gates. However, there has been a recent trend for side-hung smaller gates, and in some cases top-hung flaps have been converted to side-hung gates (Figure 6.13).

Gates tend to remain in the position to which they were last pushed by the flow, and may remain open after water levels have equalised. As a result, the gates may slam shut once the tide really starts to flow landwards. They may also tend to swing with wave action when there is little flow in either direction. For this reason, gates are often only used in more sheltered sites.

The top-hinged tidal flap (round or square) is the most common design found in tidal and fluvial situations in England and Wales. The flap can be made of many different types of material. Traditionally, they were made of wood or cast iron. More recently, lighter weight plastic, fibre-

glass or rubber compounds have been used. The flap can be attached directly onto the pipe. However on many outfalls the pipe comes complete with:

- headwalls;
- a concrete apron or basin to prevent erosion and build-up of sediments;
- a winch to hold the gate open for clearing debris.

This set-up further restricts fish migration by leaving a vertical drop (perched) from the pipe exit to the concrete platform. This drop acts a total barrier to fish migration until covered by the incoming tide or by raised fluvial water levels.



**Figure 6.5: Square, top-hinged tidal flap gate**

Flap-gate technology for flood prevention and land drainage has improved significantly in recent years. A wooden flap gate would warp and not seal completely. Today's flap gates can achieve almost an almost complete seal. When closed, they create a total fish barrier. The heavier the gate, the greater the hydraulic head difference that is needed to open it. So when the gate is open, the water passes through at high speed. This makes fish passage very difficult, particularly for poor swimmers such as eels. When hydraulic head drops, the gate closes very quickly.

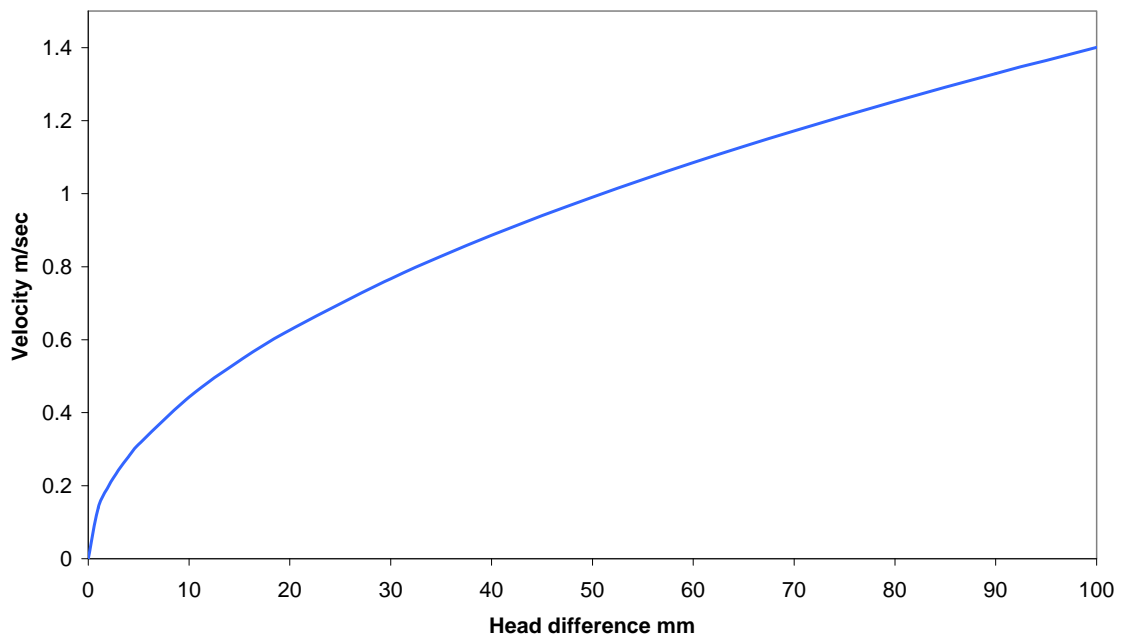
## 6.1 What are the issues?

Tidal flaps prevent fish and other biota from moving freely. They are a particular issue for small eels migrating landwards because of their limited swimming ability. Solomon and Beach have reviewed the information on the swimming ability of elvers (2004a). They found that the burst speed of an 80 mm elver is generally about 0.5 m/sec, varying with temperature and between individuals. (Burst speed is a speed that can typically be maintained for 20 seconds.)

The theoretical relationship between hydraulic head and the velocity of water passing through a gap is shown in Figure 6.6. On this basis, a head difference of only 12.7 mm would generate a velocity of 0.5 m/sec. In practice, edge effects would reduce the velocity through a narrow gap. However elvers would still be unable to overcome the water speeds generated by even very small head differences. These figures tally with



the conclusions of Wood and Blennerhassett (undated), who concluded that heads in excess of 15-20 mm would defeat elvers.



**Figure 6.6: Theoretical relationship between head difference and the speed water travels through a gap.**

As already described, the commonest form of tidal flap is a circular or square top-hung gate. This closes under its own weight, and is held open by the seaward flow when the landward level exceeds the seaward.

The seating face is often sloped to aid self-closing. This means that the door closes while there is still a positive head on the landward side. As the gate closes, the flow around the gate is moving quickly – beyond the swimming ability of a small eel. The situation is further complicated by the route that water takes during low freshwater flows.

Tidal flap apparatus has to be large enough to cope with the highest flow that is likely to occur. So it is nearly always handling only a very small fraction of its maximum capacity. Low flows are of course common during the months when small eels migrate landward – typically April to September. The flap will only open to a small extent, with the flow ‘squirting’ sideways through a small gap (Figure 6.7). This is in fact a worse situation for larger fish of all species than it is for small eels.

In recent years, there has been a move towards installing structures with two tidal flaps in series (Figure 6.8). This offers greater protection to industrial or residential property that would be at risk if a single control device failed. However the design is not helpful to eels: it rules out the possibility of a flap being occasionally held slightly ajar for a tide or two by a stick or plastic bottle. This would allow water to flow inland and eels to pass (see Figures 6.9 and 6.14).



**Figure 6.7: Water squirting through the gap of an almost-closed rectangular tidal flap at the mouth of a marsh drainage channel on the Thames Estuary. Even when the tide rises to the bottom of the door, this flow is too fast for elvers to overcome. As the velocity starts to fall, the gate shuts.**

Tidal flaps are now a major impediment to the landward movement of elvers and small eels. However small elvers are remarkably adept at exploiting small leakage flows and occasional failures in defences – such as debris holding a flap slightly open for a tide or two. Since tidal flaps used to be imperfect seals, they probably allowed regular passage. These factors may explain why there have been few observations of a complete lack of eels within areas protected by tidal gates. The presence of eels may be the result of a short window of opportunity once every several years. However it is important to be aware that modern designs for tidal flaps may effectively be fish proof.

The ideal situation would be for elvers and young eels to have some opportunity of landward passage for at least a short time on each tide – the rest is up to them.



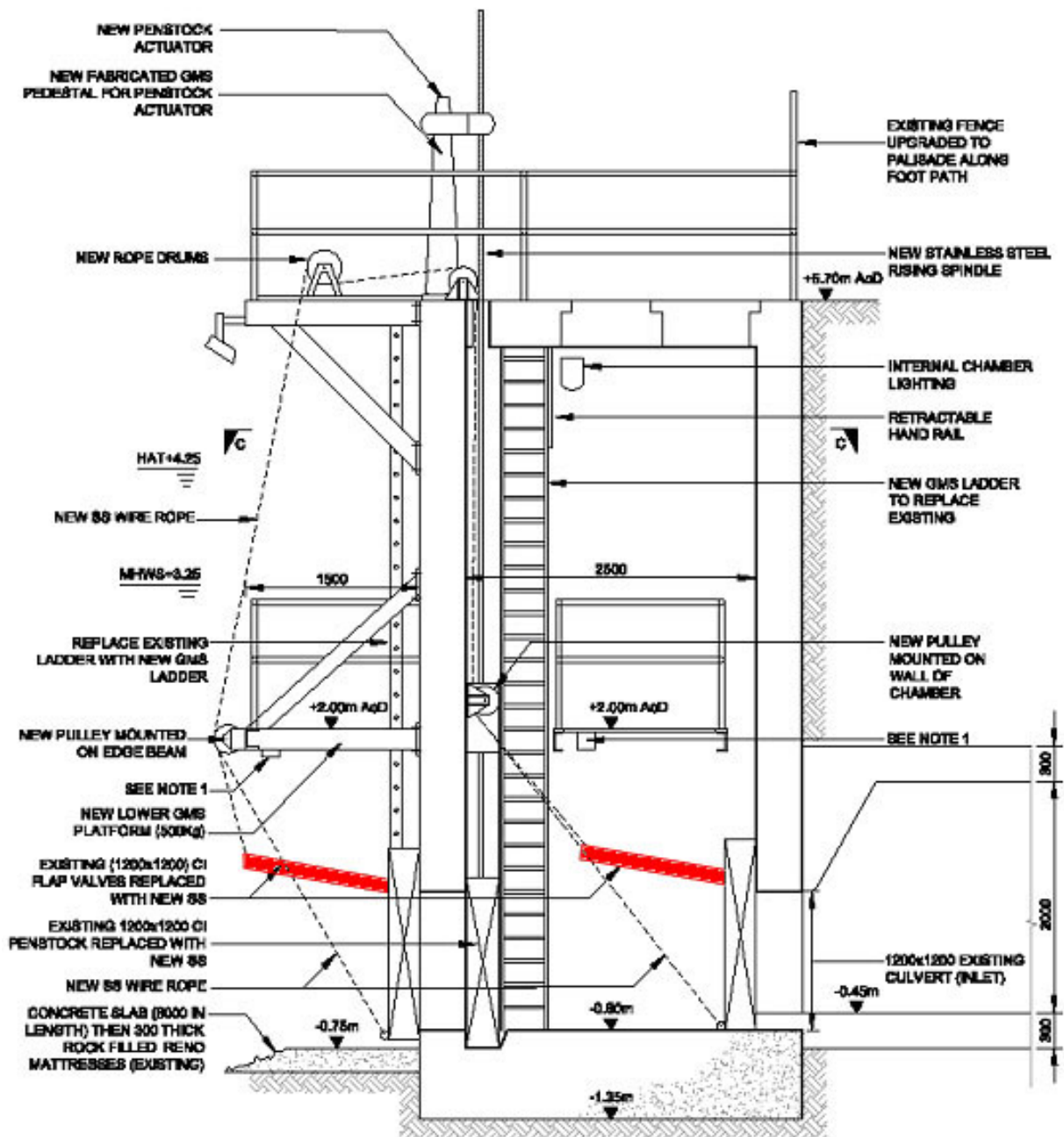


Figure 6.8: Section through the tidal control structure at the outlet of a marsh drainage system at Barking Creek in Essex. There are two 1,200 mm square-section cast-iron flaps. These are in series (highlighted in red, held wide open) with a penstock between.



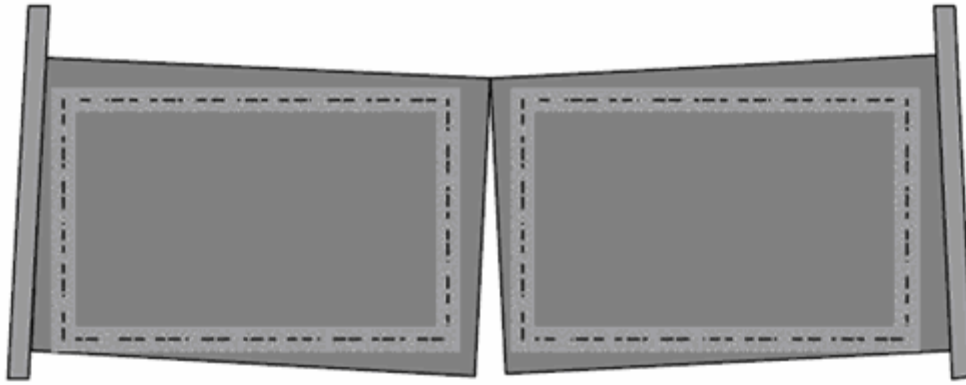
**Figure 6.9: The outer flap in the structure shown in Figure 6.8. Note the two plastic bottles jammed in the flap which prevent the flap from closing completely. Were this a single flap, the jammed bottles would allow some landward flow and the passage of elvers. However, the presence of a second flap a couple of metres behind this one prevents this.**

Tidal doors are generally considered benign for eel and elver passage, and indeed for other species of fish. They tend to remain fairly wide open throughout the ebb tide and ensuing slack water. This allows strong swimmers, such as salmon and sea trout, to pass inland throughout the ebb tide. It also allows weak swimmers such as small eels and elvers to travel inland for a significant period: towards the end of the ebb, over slack water, and for a short time on the flood. Firth (undated) studied 59 tidal structures on waterways draining to the Humber Estuary, between Spurn Head and Boothferry Bridge on the Ouse and Keadby on the Trent. He concluded that, in most situations, tidal doors had little effect on fish movement, when compared with tidal flaps.

## 6.2 Options for fish passage at tidal flaps

### 6.2.1 Replace with tidal gates

One option is to rotate the hinges hanging the gate from the horizontal to near the vertical. Do not make them entirely vertical as the weight of the gate would not then help to shut it. You would have to modify the hinge in order for the structure to cope with the weight of the gate, and to physically prevent the gate from opening too far. The change will allow the gate to open far more easily, to a greater extent, and for longer. In addition, fish can enter from the side more easily than they can from below.



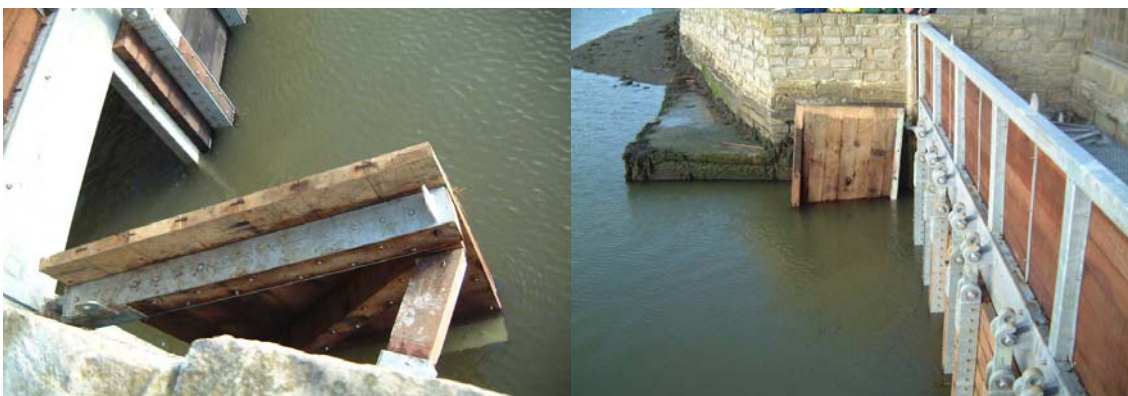
**Figure 6.9: Large side-hinged gates are angled inward, providing a small closing force, and are typically mounted over large rectangular culverts.**

Side-hinged gates are now available commercially. Large, side-hinged rectangular doors made of aluminium or stainless steel are attached to square or rectangular concrete culverts (see Figures 6.10 and 6.11). Although the gates can weigh more than a tonne, they open easily under relatively little water pressure from upstream. Some side-hinged gates may require only one inch of water level difference to open up to 45° (Coos Watershed Association, unpublished data). Such wide opening is expected to allow much better fish passage than would be normal with top-hinged tide gates.

You must install the top hinge closer to the culvert opening than the bottom hinge. This gives the tide gate a slight downward tilt, which restores the tide gate to the closed (default) position at the end of the ebb tide (Charland 1998, 2001).

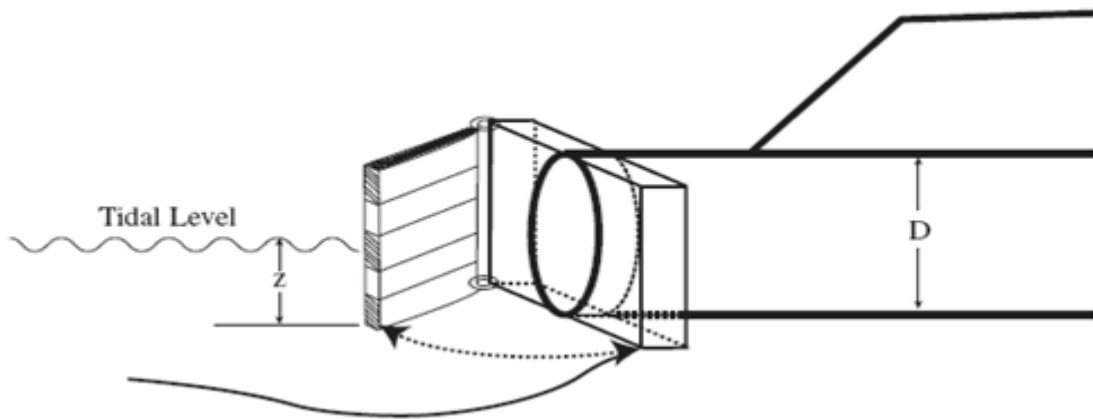
Side-hinged tide gates do have a major disadvantage: it is more difficult and costly to build the support structure needed to hang such gates. The gate must be installed at precise angles from the vertical. It must therefore be placed in a structure that will not change its orientation over time. It also needs to be suspended using strong hinges that are resistant to corrosion (Charland 2001). If the angle of the support structure does change, the door will either not open properly or will not close during flood tide. Great care must be taken to install the gate at the correct angle of tilt, because the angle will be very difficult to change later on.

Side-hinged tide gates are reported to provide better fish passage, upstream water quality, and estuarine connectivity than the traditional top-hinged gates. However, neither design is entirely fish or environmentally friendly. The basic problem is that both types are very good at doing what they were designed for, namely removing the influence of high tides on upland water levels.



**Figures 6.10 and 6.11: Side-hung gate on the River Avon, Hampshire.**





**Figure 6.12: Side-hinged, rectangular tide gate.**

Side-hung tidal doors overcome many of the problems for the passage of elvers and small eels. And they do not appear to have any inherent disadvantages compared to tidal flaps. We recommend the use of this simple alternative wherever it is viable.



**Figure 6.13: Side-hinged gates are fitted to replace top-hung flaps at Schneider Creek, Washington State, US.**

Photograph courtesy of Tom Slocum, Washington Conservation Districts North West Region Engineering Program.

The issue here was the passage of coho salmon. The right-hand gate is fitted with a muted tidal regulator.

### 6.2.2 Pegging flaps

Pegging flaps causes them to remain slightly open throughout the tidal cycle. This 'unofficial' practice was once fairly widespread on the Essex marshes (John Claydon,

personal communication). The practice involved placing a small piece of wood to hold the door ajar (see Figure 6.14). The aim was to keep the field ditches wetted in dry weather by allowing some landward flow. These ditches often acted as stock fences between adjacent fields. When major rainfall opened the flap further, the piece of wood would be released and washed away.

This practice could be a way of improving elver passage during the relevant months of the year, provided the relevant permissions were obtained. However, caution must be exercised: if you peg just one side of the flap, rather than the bottom or both sides, the peg may cause damage to the gate structure – especially where the head on the tidal side of the flap is considerable.

Pegging may also cause the build up of silt. This can be an undesirable side-effect of several of the options considered here. In many cases, the tidal water outside the flap may be turbid with a high silt load. If some tidal water is allowed to pass, silt may be carried landwards and deposited in the quieter flows there.



**Figure 6.14: A pegged tidal flap: a piece of wood at the 3 o'clock position holds the flap ajar.**

### **6.2.3 Naturally open flaps**

Most tidal flaps close naturally close under neutral conditions, by virtue of their own weight or a backward slope to the sealing face. However, there are ways to ensure the gate can remain in a naturally open position under neutral conditions, closing only when a seaward head builds up and/or there is significant landwards flow:

1. One approach is to position the sealing face with a forward slope, such that the gate is slightly open when hanging in a vertical position. Any significant flow landwards will cause the gate to close.



2. A simpler approach is to use a chain or cable rigged to an eye on the flap, and supported in some way in front of the flap (see Figure 6.15). This does not require any significant modification to the installation. The weight of the chain, or a weight attached to the cable, can be adjusted until the gate is just held open under neutral conditions by a catenary action. Again, any significant landward flow would shut the gate. This option is probably only realistic where the structure readily allows the cable to be held well in front of the gate, for example where the flap lies within a channel as in Figure 6.15.



**Figure 6.15: Two metre square section tidal flap at Havering, Essex. This drains an area of Havering Marshes to the Thames Estuary.**

(The weight of the chain and cable reduces the closing weight of the door, delaying closure. Additional weight would hold the flap open after water levels have equalised on the rising tide. Note that the chain and cable were not installed for this purpose.

#### **6.2.4 Permanent gap**

A small gap, permanent or seasonal, allows elvers and small eels to pass when water levels allow. It recreates the effects of the imperfect seal that was common to most flaps before modern materials and manufacturing methods created good seals.





**Figure 6.16. The nearer flap is fitted with a mitigator fish passage device, which holds the door ajar until the rising tide lifts the floats. The further culvert has a side-hinged gate, converted from a top-hinged flap – the remains of the flap hinges can be seen on top of the concrete bulkhead. Photograph courtesy of Guillermo Giannico, Oregon State University.**

There is a range of options for creating such a gap. They include holes drilled in gates, and devices to hold the door open a small amount. For elvers, a gap of just a few millimetres is likely to allow passage for a short period when water levels equalise. And if the gap were fitted with a crawling substrate, it could allow elvers and small eels to make progress against a stronger flow – and thus at greater heads and for longer on each tide. An arrangement of rigid pins may be more effective than conventional flexible substrates. These pins could vary in diameter and spacing for eels of different sizes.

A good approach might be to develop a device that can be readily fixed and removed from a flap. This is basically an extension of the pegging principle and would allow seasonal deployment (see Section 6.2.3).

A significant drawback with permanent gaps is that they allow water through for much longer than is actually useful for migration. Elvers are likely to be attracted to an outfall by the seaward flow of fresh water. Once the tide starts to flood, the small gaps left around the flap would be unlikely to attract elvers from very far a field. This is in contrast to the strong landward flow that would occur if the flap were fully open or not installed at all. A 'permanent gap' would really only allow elver passage for a relatively short time around level equalisation. A better approach may be to use slow-closing flaps. See below.

### **6.2.5 Slow-closing flaps**

Slow-closing flaps are a logical extension of permanent gaps. The gap would be open only when eels and elvers could make use of it, rather than throughout the tidal cycle. This would greatly reduce the extent of tidal intrusion and may allow the gap to be somewhat larger when passage is possible.

It may be possible to arrange for the flap to have 'stiff' hinges for the last (say) 10° of closure. A positive pressure would be required to close it. The engineering options for this have not been explored, and it may prove difficult to make such a device reliable or fail-safe.

A better approach may be to have a device set away from the hinges which delays closure. Possibilities include coil springs, or rubber ball set into a cup mounting. The increasing pressure as the tide rose would compress the spring or ball, closing the gate. The same mechanism would open the gate slightly just before equalisation on the falling tide, again giving elvers access.

### **6.2.6 Mitigator fish passage device, Nehalem Marine**

This device is similar in design to self-regulating tidal flaps (see Section 7). It is included here because the device is intended to allow fish passage rather than significant tidal intrusion. Floats are mounted on a lever system attached to the gate. These operate cams which bear upon the bulkhead onto which the gate is mounted, holding the gate open a short way for part of the tidal cycle. As the tide rises to lift the floats, the cams are turned. This allows the water pressure to shut the gate.

### **6.2.7 Elver passes**

An elver pass may be a viable option at some sites, as an alternative to passage through a flap culvert (see Section 4). This may be a preferred option where any risk of landward flow is unacceptable. This landward flow is likely to happen with many of the options discussed so far.

# 7 Self-regulating tidal flaps and gates

## Background

In recent years, tidal flaps have been developed that allow controlled tidal intrusion. They allow a degree of tidal interchange and let salt water enter the area draining to the structure, usually for conservation purposes.

Several studies have examined the ecological changes that happen if tidal and salt waters are excluded. See for example Johnston *et al.* (2003), Giannico and Souder (2004) and Kroon and Ansel (2006).

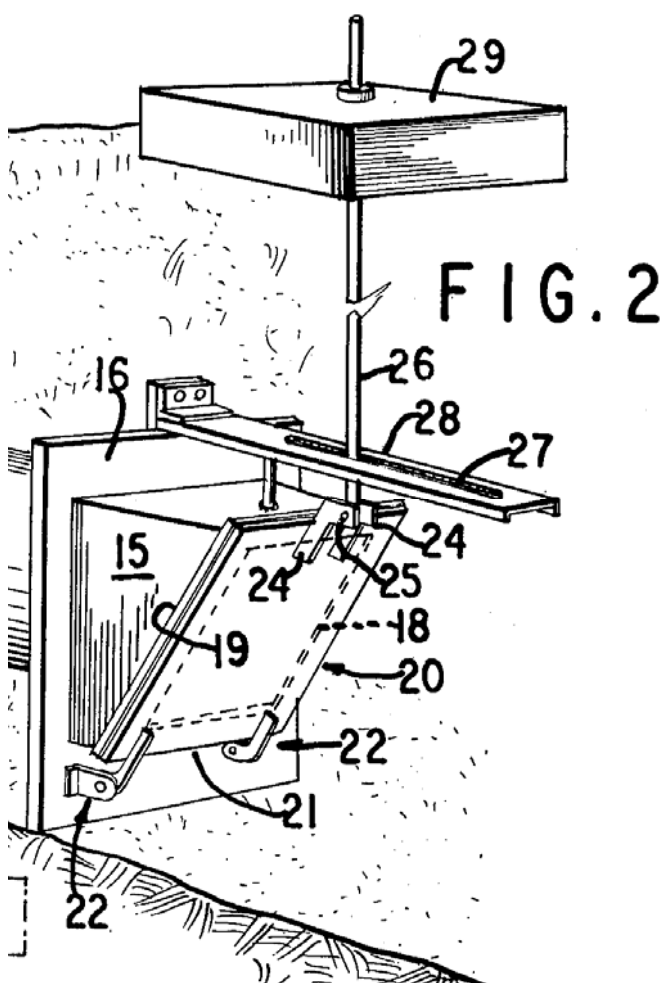


Figure 7.1: Drawing from US Patent 3,974,654, 'Self regulating tide gate', dated 17 August

There is increasing interest in allowing some tidal intrusion into wetlands which are at present cut-off from tidal influence by tidal flaps and gates. Such intrusion is usually referred to as regulated tidal exchange, or RTE. Rupp and Nicholls (2007) published a map showing proposed sites which could benefit from this approach throughout north west Europe. The map included several sites in England and Wales.

Where the gates are under manual or automatic control, the operating regime can be modified to manage RTE. Several self-regulating tidal gates have been developed. These are basically modified tidal flaps that allow RTE without the need for power or supervision. Most designs are fitted with floats which hold the gate open for part of the tidal cycle, but close the gate at some stage during the flood. The earliest reference found to such a device is shown in Figure 7.1.

Figure 7.2 shows an Australian development of this type (Green and Pease 2007). The gate is held open during the first part of the flood tide by the weight of the float and its associated metalwork. As the tide rises it lifts the float, gradually shutting the flap. On the falling tide the weight of the float opens the flap wider than normal, even at very low seaward flows. You can adjust the water level at which the gate closes by re-arranging the alignment of the float.





**Figure 7.2: Automatic tidal flap in New South Wales, Australia.**

## 7.1 The Waterman SRT

The Waterman SRT is manufactured by Waterman Industries in the US. Two of these gates have been installed in the UK: one at Goosemoor on the estuary of the Exe; the other at Cone Pill, a small stream draining into the Severn Estuary (Figure 7.3).



**Figure 7.3: Waterman SRT**

The Cone Pill structure was the first of its type to be installed, in 2004. Matthews and Crundwell (2004) describe the installation, operation and lessons learned.

## 7.2 The Williams SRT

A different style of SRT device has been developed by Mike Williams from the South West Region of the Environment Agency.

The requirements were exacting. The gate had to be closed at high and low tides, but open at an intermediate stage – so that the water passing landwards was saline rather than backed-up fresh water.

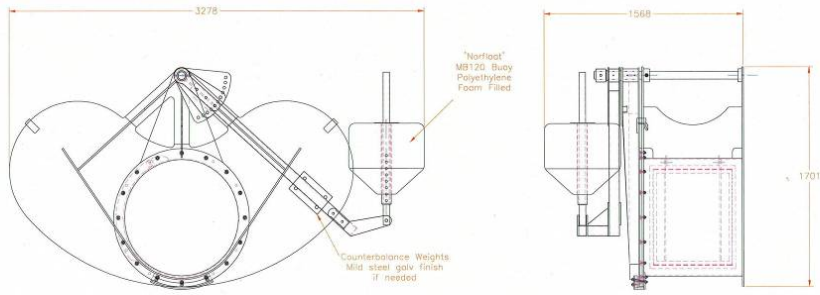
The device is fundamentally a steel plate that rotates across the mouth of a circular-section culvert (Figure 7.4). A weighted float rotates the plate. The operating sequence is shown in Figure 7.5.



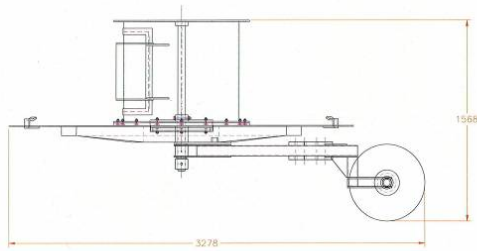
The prototype was installed on an outfall on the estuary of the River Axe in January 2009, and has so far operated without significant problems.

A second device is shortly to be installed in Hampshire, where it will replace one of the tidal flaps in the Lymington causeway. This will allow RTE into the reed bed area which had been part of the tidal estuary of the Lymington River until the causeway was built in 1731.

**Figure 7.4: Williams SRT during installation on the Axe Estuarv. Devon**

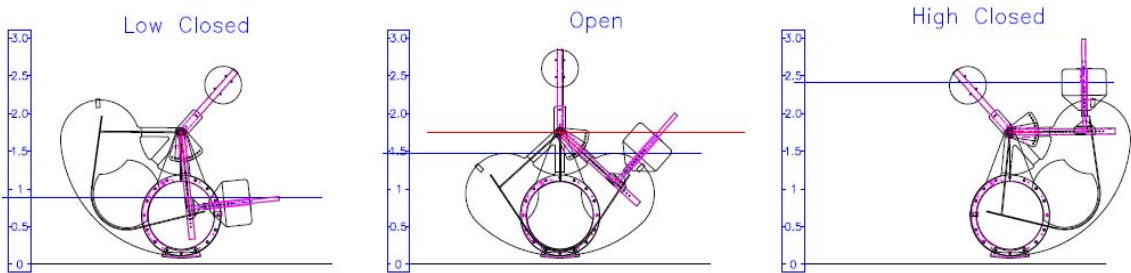


All 316 Grade Stainless steel construction  
 All Welds Continuous Fillet welds  
 Counterbalance Weights Mild steel galv finish if needed



<b>STONEMAN</b> ENGINEERING (SW) LTD <small>Park Works Station Road Wilsand Culterton Devon EX13 3QX Tel: (01894) 820355 Fax: (01894) 821533 E-Mail: stone@stoneman-engineering.co.uk</small>	
Drawing number (Job Number)	Customer
66155	Environment Agency
Drawn by	Title/Name
SK	Tidal Valve
Date	Rev
16/10/08	Rev2

W:\24\_Plan\02\021008\01\01\01 Environment Agency Tidal Valve Rev 2.dwg

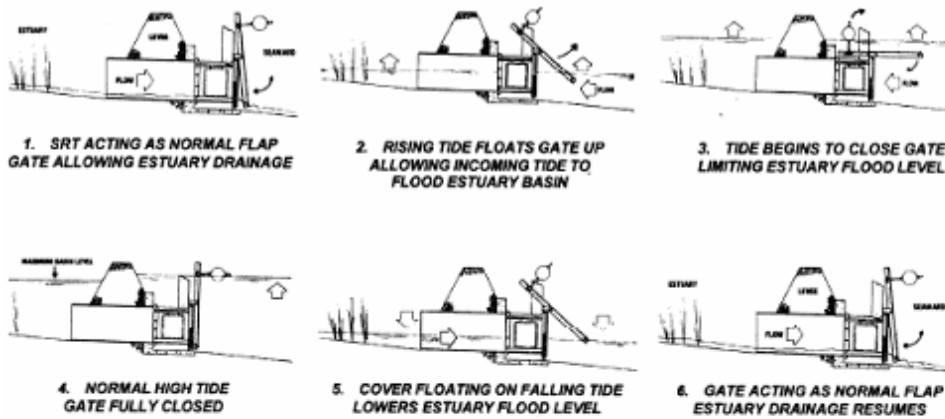


<b>STONEMAN</b> ENGINEERING (SW) LTD <small>Park Works Station Road Wilsand Culterton Devon EX13 3QX Tel: (01894) 820355 Fax: (01894) 821533 E-Mail: stone@stoneman-engineering.co.uk</small>	
Drawing number (Job Number)	Customer
66155	Environment Agency
Drawn by	Title/Name
SK	Tidal Valve
Date	Rev
16/10/08	Rev4

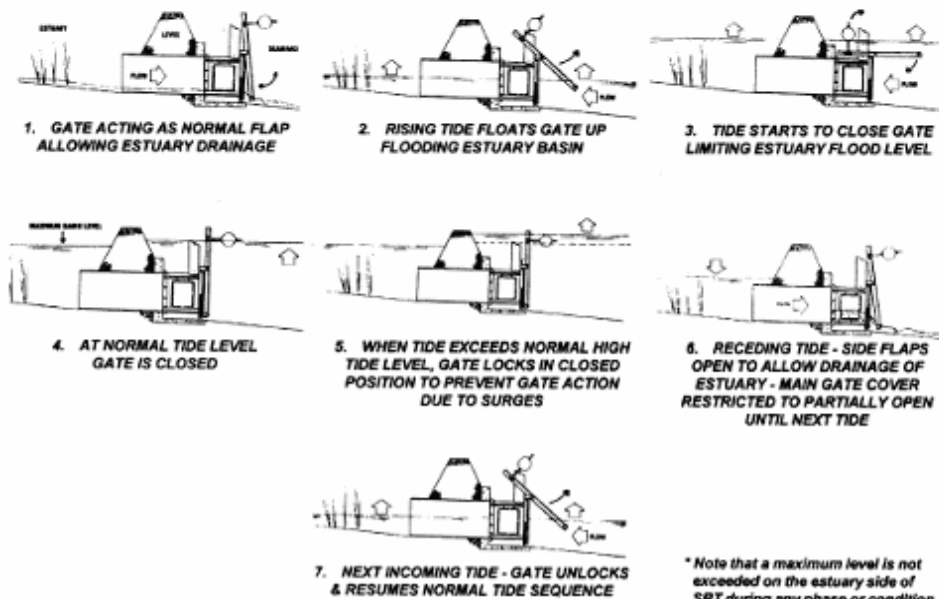
Figure 7.5: Design details for the Williams SRT



### SRT IN NORMAL TIDE SEQUENCE



### SRT IN STORM SEQUENCE \*



\* Note that a maximum level is not exceeded on the estuary side of SRT during any phase or condition.

Figure 7.6: Operating sequence of the SRT under both 'normal' and 'flood' conditions. (Courtesy of Waterman Industries Inc)

### Suppliers

Stoneman Engineering  
 Address: Park Works, Station Road, Willand, Cullompton, Devon, EX15 2QA.  
 Phone: 01884 820369

### Watermans, US

Address: Watermans, P.O. Box 458, Exeter, California 93221.  
 Phone: 559-562-4000  
 Fax: 559-562-2277  
 Website: [www.watermanusa.com](http://www.watermanusa.com)  
 E-mail: [waterman@watermanusa.com](mailto:waterman@watermanusa.com)

## Advantages and disadvantages

Advantages	Disadvantages
Requires no maintenance of electrical power supply	Relatively expensive
Adjustable manually to operate over a specified range	Not tested to Flood Risk Management specifications
Robust, requires no more maintenance than a standard flap gate	Floats can collect debris and need to be cleared
Opens fully, allowing easy fish passage	
Can be fitted as the total flap gate, alongside a normal gate or within an existing flap gate	

## What might you need to do to build this?

- Flood modelling
- Permission of landowner
- Flap gate design
- Fabrication firm to build and fit
- Development control consent
- Local authority planning consent (change of land use)

## Table of contacts: name, contact details and experience

Name	Contact details	Experience
Mike Williams (Technical Specialist, FRB)	Exminster House, Exeter Internal 7 24 6033 External 01392316033 <a href="mailto:Mike.williams@environment-agency.gov.uk">Mike.williams@environment-agency.gov.uk</a>	Science report: Regulating tidal exchange. Installation of fish-friendly flap gate on River Axe, Seaton
Charles Crundwell Senior Technical Specialist	Riversmeet House, Tewkesbury Internal 7 22 4374 External 01684 864374 <a href="mailto:Charles.crundwell@environment-agency.gov.uk">Charles.crundwell@environment-agency.gov.uk</a>	SRT Cone Pill Gloucestershire. Improving connectivity between the North Sea and the tidal Trent

## 7.3 Muted tidal-regulated (MTR) gate, Nehalem Marine.

In this interesting example, the gate is controlled by the water level on the landward side of the structure. This is usually the target of regulation. A float on the landward side operates the gate using a series of levers and a rod that projects through the structure (see Figures 7.7 and 7.8).



**Figure 7.7: Float mechanism for an MTR gate at Schneider Creek, Washington State, US. Photograph courtesy of Tom Slocum, Washington Conservation District's North West Region Engineering Program.**



**Figure 7.8: Gate actuating mechanism for an MTR gate at Schneider Creek, Washington State, US. The door is being held open. Photograph courtesy of Tom Slocum, Washington Conservation District's North West Region Engineering Program.**



## 7.4 Variable backflow flap gate (VBFG™), Juel Tide Gates

This variable backflow flap gate (VBFG™) builds on the principle of the slow-closing flap described in Section 6.2.5. In the original design, the gate was held open by a hydraulic cylinder until the flow of water landwards – and the head acting upon the open gate – exerted enough force to overcome the cylinder. The gate then closed. Current models use a shock-cord rigging arrangement to create the same effect. When the rigging is correctly balanced, the tension increases as the gate closes. This prevents the gate from slamming shut. A major advantage of this design is that the gate is either fully open, or is closed. The rigging can be adjusted to effect closing with almost any level of tidal intrusion.



**Figure 7.9: Juel Variable Backflow Flap Gate (VBFG™). The gate is fully open, on the ebb tide. Photos reproduced with permission from Juel Tide Gates of Seattle, Washington, US ([www.jueltide.com](http://www.jueltide.com)).**

The gate is made from heavy-duty, 316 stainless steel and copolymer. It is designed to require minimal maintenance.

## 7.5 Mouse holes, cat flaps and pet doors

There has been a lot of work done on using a 'cat flap' approach to allow some water to flow through a larger flap. The idea is that the flow of water through the smaller flap is very much less than the capacity of the larger 'parent' gate.

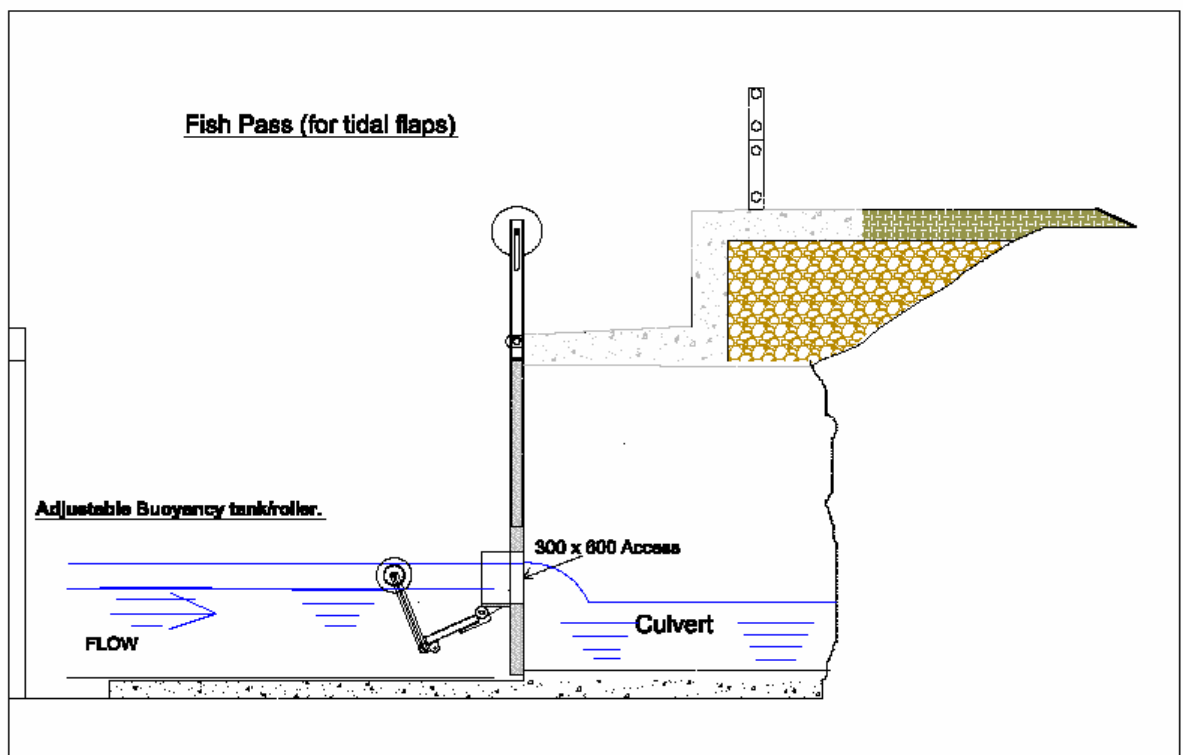
The smaller flap is light and can be held open much wider, and for a longer period, than the larger gate. Depending on its size, the cat flap can be made of very lightweight material. There is also the scope for a mechanism that holds the cat flap open for much longer than it would stay open naturally. This is rather like an SRT which delays closure of the whole of a large flap (see Section 8), but the mechanism can be very much lighter and cheaper. The consequences of failure are also very much reduced in comparison with what would happen if the main gate remained open when it should be closed.

A float-operated cat flap has been installed in a massive tidal flap on the River Gilpin in Cumbria. The gate was manufactured by Aquatic Control Engineering and installed in 2009. Some details are shown in Figure 7.13. The cat flap is relatively large (1,000 mm wide and 400 mm tall) and is designed for the passage of sea trout. It is top-hinged and held open by a sliding float arrangement. When the tide rises to the limit of travel of the float, water flows down a pipe into the float, causing it to fall. This allows the cat flap to close. The float drains on the next low tide, commencing the cycle once more. The performance of this system has been monitored by Ben Bayliss from the Environment Agency's North West Region.

There has also been work done in the US on the scope for using a bottom-hinged cat flap, which is naturally open until lifted by a float. The idea appears to have been originally proposed by Charland (1998). According to Jeff Juel of Juel Tide Gates, only a few devices were installed and these subsequently failed and were removed. No details of the problems are available. A similar design is to be installed in the tide gate on the River Stiffkey in Norfolk, to allow access for sea trout. Details are shown in Figures 7.11 and 7.12.



**Figure 7.10: Tidal flap at Maydays Farm, Essex. This is an interesting installation as the flap is separately hinged in two halves. The lower half is fitted with a small 'cat-flap', presumably designed to operate at very low flows. However this cat flap, which is made of cast iron, is too heavy to make a useful contribution to elver passage.**



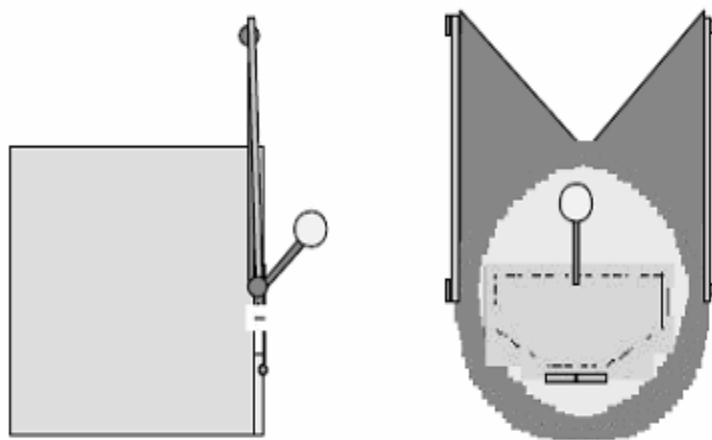
**Figure 7.11: Section through tidal flap on the River Stiffkey showing the proposed bottom-hinged cat-flap in an open position. Drawing shown with permission of Sandy Cowie.**



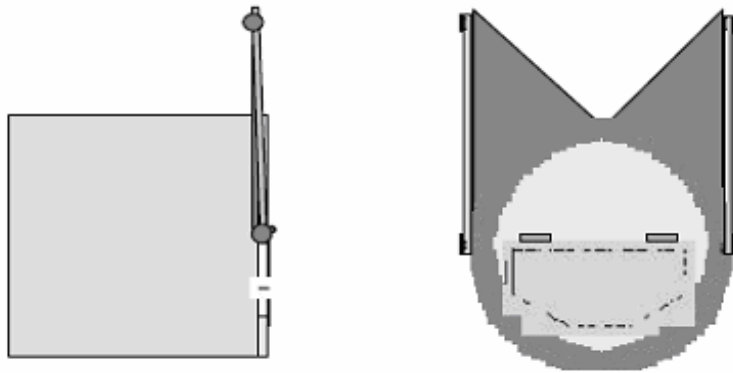


**Figure 7.12: Bottom-hinged cat flap, to be installed in the tidal flap in the River Stiffkey. The door is in the closed position, with the float in the high-tide position. The dimensions of the opening are 600 x 300 mm. Photograph shown with permission of Sandy Cowie.**

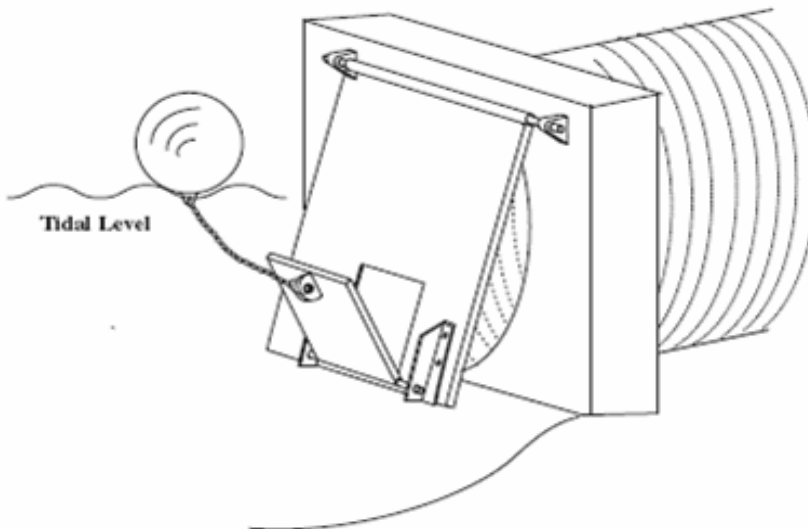
These solutions have been used primarily in the US and Australia. They allow fish migration but also re-establish tidal regimes and water quality. They are particularly helpful for reducing mosquito and pH problems. There is no reason why they could not be widely installed in England and Wales where they could improve connectivity cheaply. You would of course need to first check their suitability for a specific location by modelling the impacts of the gate.



**Figure 7.14: Design for a bottom-hinged pet door. It features a small hole in the standard door. The pet door is mounted over the hole with a float and arm assembly attached.**



**Figure 7.15: Design for atrop-hinged pet door. It features a small hole in the standard door with a small pet door mounted over the hole.**



**Figure 7.16: A bottom-hinged pet door.**



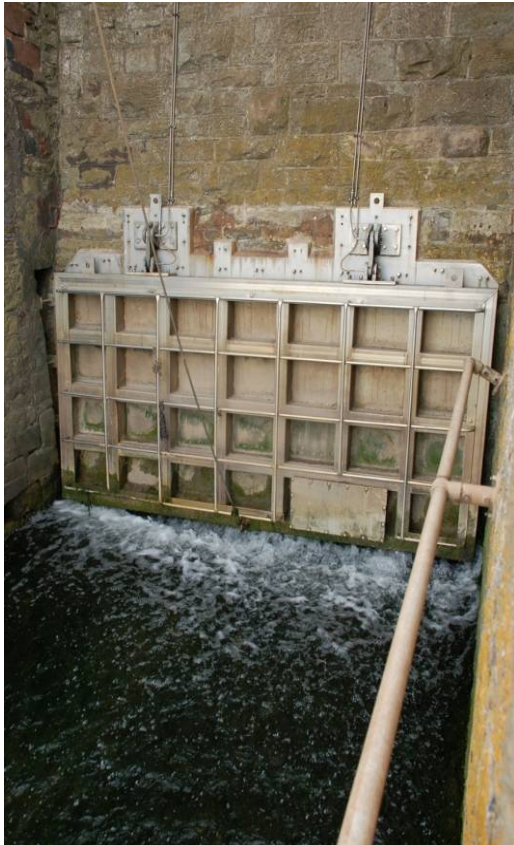
**Figure 7.17: Two mouse holes on a tidal sluice on the River Medway.**

The holes are only reached for a short duration on incoming tide. Note the roped open flap on the top left hand side. This is required as a fall-back option if the mouse hole needs to be closed.



**Figure 7.18: Mouse hole on sluices on the River Test. As the downstream water levels rise, fish can pass through hole.**





**Figure 7.19: Closed up mouse hole on tidal flaps on the River Lyd, Gloucestershire.**



**Figure 7.20: A flap gate at Warth Brook, Gloucestershire. The gate's correct invert level allows continuous opportunity for fish passage.**

### Advantages and disadvantages

Advantages	Disadvantages
Requires no electrical power supply maintenance	Can allow the build up of silt upstream
Adjustable manually to operate over a specified range	Not currently tested to Flood Risk Management specification
Opens fully, allowing easy fish passage	Mouse hole or pet door could cause blockages.
Relatively inexpensive	Small hole can create fast-moving water that prevents fish migration
Easy to remove or close if an unexpected problem occurs	FRM prefer flap gates to have drop as this helps to remove sediment
Can be retrofit	

### Suppliers

Any local fabricator.

### What do you need to build this?

- Flood-risk modelling
- Tidal or fluvial level data
- Level data
- Fabricator to adapt existing gate
- Local consents (agricultural payment schemes)
- EA Team to arrange gate removal and refixing

### Tables of contacts: name, contact details and experience

Name	Contact details	Experience
Dave Hunter	Environment Agency 01794832732	Pet door on River Yar, Yarmouth, Isle of Wight
Adrian Fewings	Environment Agency 01962764952	Mouse hole, tidal, on River Medway, Mouse hole on River Test

## 7.6 Installation of light-weight gates

The lighter the flap, the further it will open, and the longer it will remain partially open towards level equalisation. This may give elvers a few extra minutes of access on each tide. Aquatic Control Engineering manufactures a range in high-density polyethylene (HDPE), with stainless steel reinforcement, which are much lighter than their cast-iron equivalents.

Bates (1992) compared the opening of two 1.2 m diameter flaps: one made of cast iron and the other of aluminium. With a head differential of 300 mm, the aluminium gate opened to about 750 mm, the cast-iron one to 150 mm. Light-weight flaps may be most useful for eels when used in a cat-flap approach (see Section 7.4).



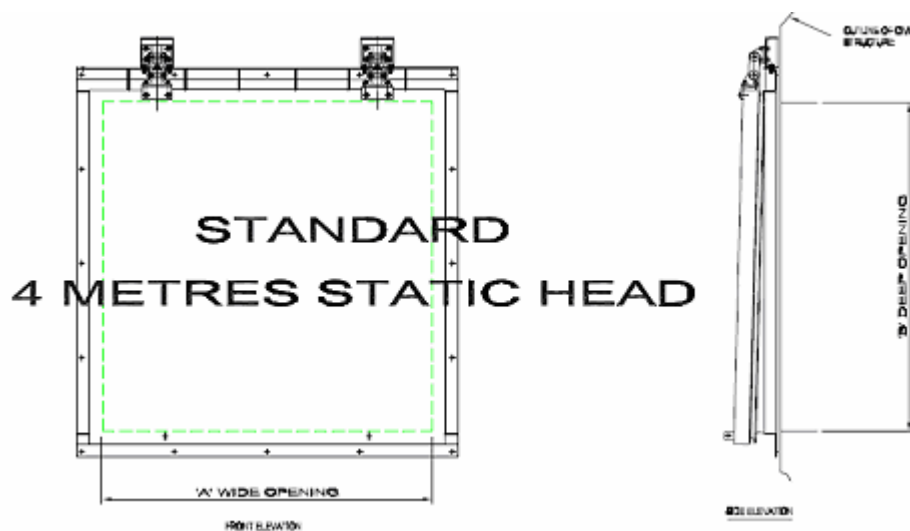
**Figure 7.21: A light-weight HDPE tidal flap, manufactured by Aquatic Control Equipment (ACE) Ltd. Photograph courtesy of ACE.**

The main reasons why flap gates prevent elvers and eels from migrating are that:

- the weight of the steel flap generally causes the gate to seal;
- when there is sufficient upstream hydraulic head to open the flap, the water velocity around the flap's edges is too great.

If the standard steel flap is replaced by a lighter design, the hydraulic head required to open the flap is reduced. The flap will open wider for longer, lengthening the time when eels can pass and reducing the water velocities around the edges.

In most cases you can replace a cast-iron, steel or hard-wood flap with one made of aluminium, plastic or fibre glass.



**Figure 7.22: Double-hung flap valve (plastic door)**



## Advantages and disadvantages

Advantages	Disadvantages
Requires no electrical power supply or additional maintenance	Some resistance from FRM in sites with a lot of floating debris. Their view is that damage to flap and vandalism may be more likely.
Opens wider than standard flap gate, which makes it easier for more fish to pass	Often only up to 600mm in size
Relatively inexpensive. Light-weight gates cost less than their heavy-weight equivalents	Electrolysis corrodes aluminium more easily than cast iron or steel (especially if a different metal is used in the hinges)
Easy to remove or replace if unexpected problem occurs	Cast iron is still the industry norm, so finding UK suppliers can be tricky
Can be retrofit, cost effective.	May improve fish passage, but do not significantly improve water quality or connectivity to a stream or an estuary

## Suppliers

Ham Baker [ww.hambaker.co.uk](http://ww.hambaker.co.uk)  
 Midland Valves [www.midlandvalve.com](http://www.midlandvalve.com)

## What do you need to build this?

- EA Operational Delivery team to arrange gate removal and replacement
- Landowner agreement

## 7.7 Counter-balanced flap gates

Putting counter-weights on flap gates, as in Figure 7.23, effectively reduces the gate's tendency to close. For any given flow of water, the gate is likely to open further, and remain open longer. By adjusting the size and position of the weights, you may be able to arrange for the gate to remain slightly open under neutral conditions.



**Figure 7.23: Counter-weighted tidal flaps on the River Lymington, Hampshire. These tend to open further and remain open longer than conventional flaps of similar weight.**



**Figure 7.24: Counter-weighted tidal flaps on the River Lymington. Shown fully open during a spate.**

Counter-balances have been installed on very large and heavy flap gates in order to help the gates open and discharge once the influence of tide has ceased. Without these counter-balances, the weight of the gates would prevent them from opening and the trapped water would pond until there was a sufficient head to open the gates. For land drainage reason this is inefficient – or even counter-productive. Counter-weights

fixed to the top of the gate aid easy opening. These balances can be so effective that it is possible for one person to open the gates fully even if they weigh several tonnes.

The counter-balances were generally installed in tidal situations on large rivers where the sheer volume of tidal water would close the gates. After the tide lock it was important for water to escape as quickly as possible to prevent fluvial flooding. The counter-balances allow the gates to open much wider than a standard flap gate would and therefore they are not such a barrier to fish as other types of flap gates.

Counter-balanced flap gates are now rarely installed. The preference now is for flap gates with more advanced designs and materials and also for automated penstocks. Where counter-balanced flaps are still used, it is possible to alter the counter-balances to make them stay open for longer. This increases the opportunity for fish to pass.



**Figure 7.25: Counter-balanced gates on the River Leadon, Gloucestershire. Note that the gates are shut because of tidal influence. They soon open wide with the ebbing tide.**





**Figure 7.26: Counter-balanced gates on the Bottesford Beck, Scunthorpe.**

#### **Advantages and disadvantages**

<b>Advantages</b>	<b>Disadvantages</b>
Requires no electrical power supply maintenance	Can allow the build of silt upstream
Adjustable manually to improve fish passage opportunity	Rarely installed now. Generally made to order, so more expensive than other options
Opens wider than a standard flap gate, allowing easier fish passage	
Less prone to blockage	
Suitable for large river	

#### **Suppliers**

Local fabricator or Environment Agency's Operations Delivery team to arrange.

#### **What do you need to build this?**

- Flood-risk modelling if gates are altered
- Tidal or fluvial level data
- Installation of continuous monitoring of water quality
- Water level data
- Local consents (agricultural payment schemes)
- EA Operations Delivery team to arrange testing of counter balances

## Tables of contacts: name, contact details and experience

Name	Contact details	Experience
Martin Hayes, Alison Hampson	Environment Agency 01543404842	Bottesford Beck
Charles Crundwell	Environment Agency 01684864374	River Leadon and Bottesford Beck

## 7.8 Automated gates

Another option is to install powered and automated sluices, with their operation linked to the tidal cycle. The benefits are that the sluice can be opened fully, and the time that it remains open can be maximised. The main disadvantages are that they are expensive to build and maintain. They are also of little use in isolated locations where there is no power.

## 7.9 Siphon passes and piped passes

### Introduction

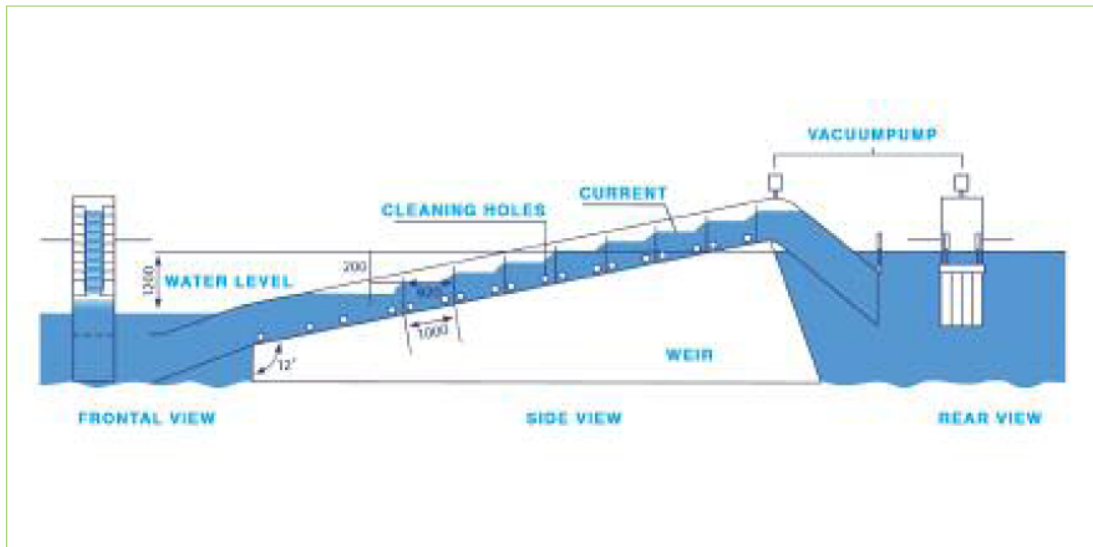
In some cases it is not desirable to let any water through a sluice gate. This may be because of the risk from flooding or for ecological reasons. The only solution for elver and eel passage will then be a closed siphon pass or pumped pass.

Siphon passes specifically for fish are new. Currently the only company developing them are Fish Flow Innovations based in the Netherlands ([www.fishflowinnovations.nl/en](http://www.fishflowinnovations.nl/en)). There have not yet been any installations in the UK. The Fish Flow siphon fish ladder is based on the principle of a poorly functioning siphon: a siphon with an air bubble. The volume of the bubble defines the flow rate through the system. This volume is controlled by a vacuum pump in order to prevent a change in flow rate due to the import or export of gas from the water. The pass is only suitable for sites where the free downstream passage of silver eels is achievable.

### Pictures and designs



Figure 7.27: Fish siphon for all species



**Figure 7.28: The inside of an all-species fish siphon.**



**Figures 7.29 and 7.30: Eel-only fish siphon. Pipe encloses eel brushes only. This siphon was installed on the River Roggebotsluis near Kampen in February 2007. The ladder enables migration of eels between Lake IJsselmeer and Lake Veluwe.**





**Figure 7.31: Newly constructed siphon pass at Hertogswetering near Berghem (Brabant) in May 2006.**



**Figure 7.32: The top of the fish ladder. Note the eel brushes which aid eel migration.**

**Advantages and disadvantages**

<b>Advantages</b>	<b>Disadvantages</b>
Can be used where no ingress of water is allowed	Requires electrical power to start siphon
Can be designed for all fish species or eel only	Installation costs
Fully adjustable flow rates to suit different fish species	Not widely available
Low power requirements	
Small footprint, so land purchase is not required	
Low maintenance	

**Suppliers:**  
FishFlowInnovations



van Twickelostraat 2  
postbus 423  
7400 AK Deventer  
the Netherlands  
t +31 570 61 92 92  
f +31 570 61 93 31  
info@fishflowinnovations.nl  
www.fishflowinnovations.nl

**What do you need to build this?**

- Planning permission
- Abstraction licence

## 7.10 Revolving doors

No information on revolving doors was available for this version of the manual.

# 8 Sluices

## 8.1 In-river structures

Generally, in-river structures fall into two categories:

- undershot – where surplus water passes under the structure;
- overshot – where water weirs over a facet of the structure.

In some places, both types of structures are used in combination.

**Examples of the main types of undershot structures:**



A. Radial gate, right.



B. Large penstock sluice



C. Small penstock sluice



D. Twin leaf gate (above)  
E. Large undershot gate (left)



**Examples of the main types of overshot structures:**



**F. Penning weir (door down)**



**The same structure (door up)**



**G. Stop log weir**



**H. Large tilting weirs**



**I. Pre-fabricated tilting weir**



**J. Older style tilting weir**

## Examples of structures that are both under and overshot:



In extreme conditions, the radial gate (A), pictured left, and the penstock Sluice gate (C), middle picture, can act as overshot structures. The twin leaf gate (E), pictured far right, can be used in either mode irrespective of flow conditions.

### Initial assessment

When you assess whether a structure is suitable for an eel pass, you must understand not only the mechanics of the structure's operation, but also how it is managed. An eel passage may not be necessary. For example, a penning weir would only obstruct passage during the winter months. Throughout spring and summer, it is flat. So the weir would not prevent upstream eel migration as this happens in the warmer months.

You should also investigate the mechanics of the river and its biology, specifically eel populations. Look at any previous survey data, including catch returns where available. The location of the candidate site within its catchment is also important as this often has a bearing on the most common size ranges of the eel likely to use a pass. This should inform key aspects of the design, such as the size (width) of the channel and the density of the bristle substrate.

Eel passes for these structures fall into two main categories: those that are gravity fed and those that are pump fed. Under these two broad headings, there are many variations which are tailored to each structure type. However all eel passes for these structures will have some things in common. These include:

- bristle substrate in some format;
- a small flow of water to the downstream and upstream elements;
- some form of cover.

Two problems are common to both types of pass:

1. ensuring the eels are 'delivered' far enough away from the weir crest not to be swept downstream again;
2. safe-guarding eels that emerge from an upstream pipe from predation or poaching.

It is possible to choose either gravity or pumped solutions at most sites. However, pumped passes tend to be used at larger sites that already have electrical supply.

Both solutions have advantages and disadvantages and we look at these in the case studies which follow.



There is a case study for each structure type and we have included a component list with suppliers for the key elements.

**Case study 1:** Large multi-structure site, with flood control and penning, at the tidal limit of a river with an eel fishery.



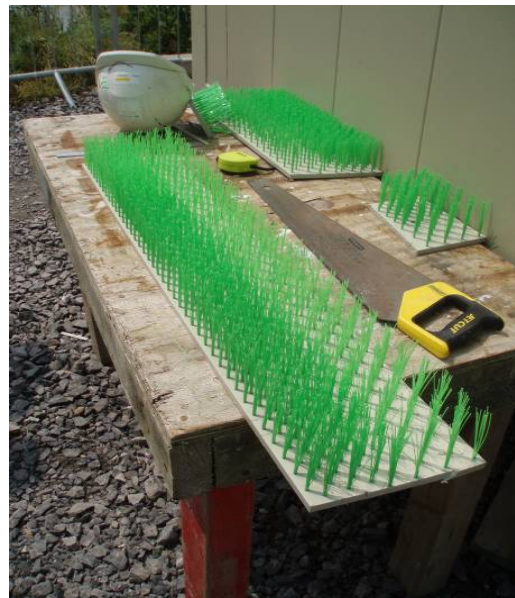
This site has an array of control structures including large penning doors. These are shown in the open position.

The doors are open during flooding and from the beginning of November to the end of March. The river is therefore unobstructed at these times.



At all other times, the penning doors are closed and the river flows down an adjacent bypass channel. The channel itself has two control structures: a tilting weir and a set of undershot sluice gates.

The same structures look very different at low tide and with low freshwater flows. This illustrates the need to identify the constraints of a site and design eel passes that will operate in very different conditions.



A pumped 'up and over' system was chosen for this site. A standard arrangement for this type of system can be seen in Figures 8.1 and 8.2.



A stainless steel channel was mounted on the inside of the sluice gate channel. This forms the downstream element of the pass. The channel was lined with twin density substrate which continues up to the apex. Here a 'splitter box' splits the pumped flow into the downstream channel and the upstream eel delivery pipe.

The term 'up and over' refers to the fact that the apex (where the splitter box and transition to the upstream pipe are mounted) is higher than the height at which water weirs over the structure.

The approximate dimensions for a pass of this size and importance would normally be:

- stainless steel channel: 300mm width x 150mm depth
- delivery pipe: 150mm diameter;
- substrate: 300mm width, 70mm tufts set in two pitches of 30mm and 20mm, cut and fitted onsite.

This installation formed part of a capital refurbishment of the flood defence structure. The contract to carry out these works and install the eel pass was awarded to: [W.S. Atkins](#) and [May Gurney](#)

This type of solution would be effective for structures A, B, C, F, G, H.

### Components

Substrate: The one in this example was supplied by: Fish-Pass France, <http://www.fish-pass.fr>

Channel: Stainless steel, bespoke, fabricated to fit by Sub-contractor to W.S. Atkins/May Gurney

Pump: Electric, continuously rated, 50 litres/ minute. Supplied as part of contract.

Installation: May Gurney

### Other information

The pass is within an enclosed structure. There was therefore no need for any form of anti-desiccation/predation lid or cover.

In order to assess how well the pass was working, a camera was installed above the downstream channel. This records any eels ascending through the bristle substrate. The camera has worked well. It has not only proved that the pass is functioning correctly, but is now used to record eel numbers in this catchment.





**Figure 8.1: The route of a typical downstream channel with substrate, the flow splitter box (blue) and the upstream delivery pipe (red).**



**Figure 8.2: The position of the pass entrance. Note that the pass will be cranked towards the bank. This is to maximise the opportunity for eels to find the flow coming down the pass –eels migrating upstream routinely stay close to the banks.**

## Case study 2: Fixed pass with pump on undershot gate

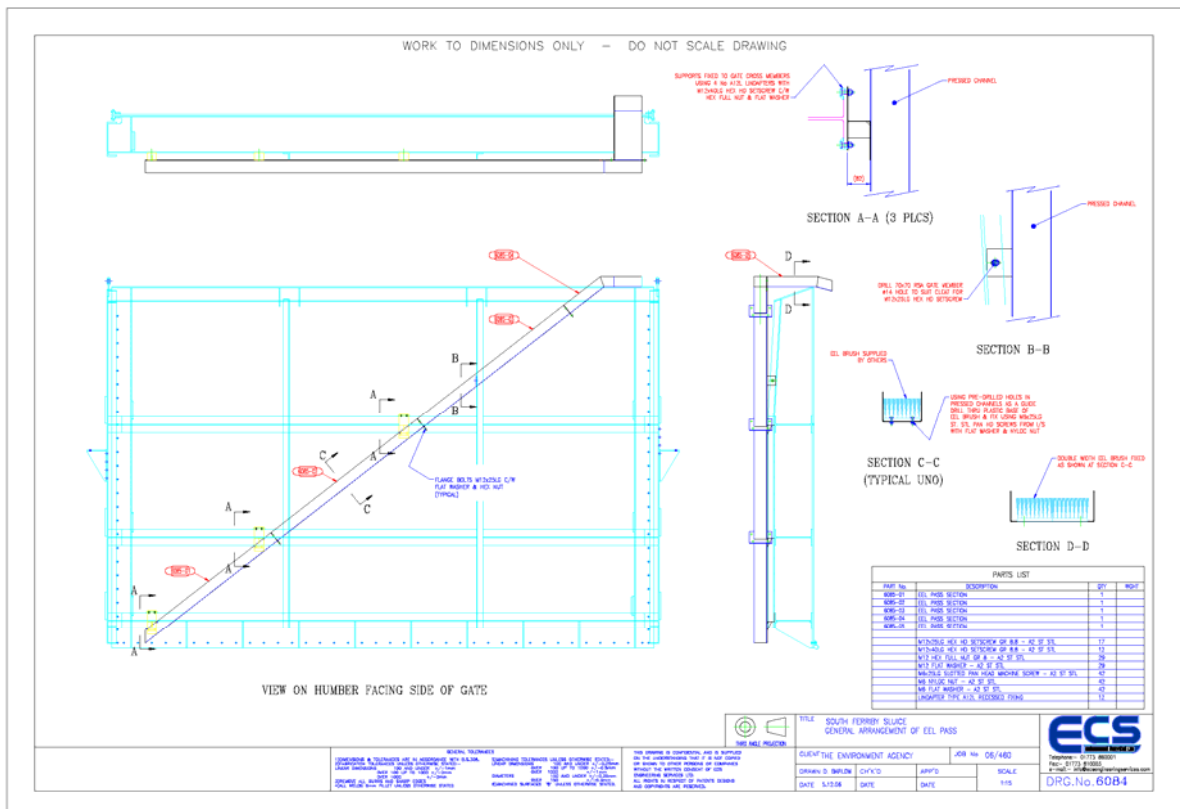


This eel pass is at South Ferryby on the Humber. It crosses a tidal sluice with a head difference of approximately 2.5m.

The pass is permanently fixed to the door, but is engineered not to foul on any other part of the structure when the door is lifted clear of the water during flood flows.

The pass is bolted to the rear of the door. It lifts clear of the water as the door is raised. The flow of water through the downstream bristle channel is jetted onto the

head of the channel. Eels ascending the pass simply drop into the upstream side of the structure. A technical drawing can be seen below.



In this instance, a bespoke fabrication was commissioned. However, the pass works on the same principle as all the other passes in this section: it has a small flow of water that feeds a bristle-lined channel.

The Environment Agency is developing a standardised channel that will be suitable for most sites. The channel will accept the most common permutations of bristle substrate. It will be prefabricated out of GRP (Glass Reinforced Plastic). The channel will be delivered in 2.4m lengths that can be added together. The units can be supplied with or



without a pre-attached hinged lid. We hope that, in many cases, this modular approach will simplify installation and reduce costs.

At the sites for case studies 1 and 2, there was existing electrical and security infrastructure. And for these particular examples it would have been difficult to maintain a constant water flow by gravity alone. A pumped pass was therefore the better option.

The disadvantage of any pumped system is that it consumes electricity. Not only is there a cost element, but at some point the pump will stop. This may be due to a power outage or to the pump's strainer becoming clogged with weed and debris. Careful design and installation can improve reliability, but a failed pump might severely impact eel migration.

This pass solution would be effective for structure D.

### Components

Substrate: 20mm gap bristle substrate supplied by Cottam Brush Ltd. Phone: 0845 434 84 36

Channel: Stainless steel, bespoke, fabricated to fit. Supplied by local contractor.

Pump: Electric, continuously rated, 110v, 50 litres/ minute. From internet supplier.

Installation: Carried out by the contractor refurbishing sluices for Environment Agency Flood Risk Management.

### Case study 3: Twin leaf gate

This twin leaf gate posed a similar problem to that in case study 2. An eel pass had to be fixed to the uppermost leaf in such a way that it could not foul on either the lower leaf or on any other part of the structure – in any gate position.

A further constraint was the proximity of the headwall. This meant that this fixed eel pass could not extend very far downstream. The only option was to increase the angle of the downstream channel.



A bespoke channel unit was made that bolts directly to the upper surface of the top leaf and moves up and down with the structure. The final angle of the downstream channel

was nearly 80°. However, the short run of the pass allows eels to manage this steep incline. A simple bag trap placed on the upstream element of the pass confirmed that eels are using this pass successfully.

The advantages of a gravity-fed pass are generally:

- there are no running costs;
- the pass is completely reliable if appropriately maintained.

One disadvantage can be a lack of flow if the pass becomes completely blocked by debris. However, this is rare in a well-installed pass, where the bristles act as a strainer for surface weed but still allow water down the channel.

The installer must also be confident that the eels are getting safely beyond the influence of the weir crest. This can depend on flow.

This solution is appropriate for structures C, E, F and G.

### **Components:**

Substrate: Bristle board with 30 mm spacing between clumps supplied by Fish-Pass France

Channel: Bespoke stainless steel channel, 200mm wide. Supplied by ACE Fabrications

Installation: ACE contractors.

### **Case study 4: Flood defence**

This flood defence structure has two large tilting weirs. It is at a freshwater site some eight miles from the tidal limit.

One obvious constraint was that any eel pass must not interfere with the tilting action of the weirs.

Due to the width of the river at this point, it was decided to have an eel pass on each side. These were mounted as near to the bank side as possible in order to intercept upwardly migrating eels. The flow down the eel passes is relatively tiny compared with the river flow over the weirs. However, the eels found and used the passes in large numbers within 24 hours of installation.







The tilting weir used at this structure is a bucket type. This made it possible to attach the eel pass channels directly to the mass concrete side walls of the structure. The stainless steel channel was prefabricated offsite then cut to fit on site. It had various cranked elements to clear the workings of the tilting weir and was also pitched at a steeper angle of around 55°. This angle was needed to avoid the lower end of the pass fouling on the telemetry sensors for the site. A CCTV system was installed to monitor the performance of the pass.



This picture shows the bespoke flow splitter box. It is basically an interceptor which sits at the apex of the downstream bristle channel and the upstream pipe. It distributes the pumped flow to these two elements of the eel pass.

The upstream delivery pipe terminates into broken, rocky substrate. This provides the eels with more than one exit so that they are not an easy target for predators.

This pass solution would be effective for structures A, B, C, F, G and H.

### Components

This installation was part of a capital refurbishment carried out by W.S. Atkins and May Gurney. The substrate was supplied by Fish-Pass France.

### Case study 5: Pre-fabricated tilting weir



This pre-fabricated tilting weir replaced a leaking stop log structure. The previous structure would probably not have hindered upstream eel migration: the plant growth that often colonises such weirs acts as a substrate. Eels were able to climb up it, through it and into the penned water level.

This new structure is typical of penning weir upgrades.



The key problems with these weirs are:

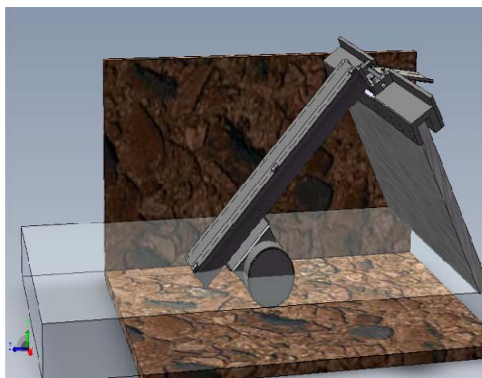
1. Modern 'clean' materials such as stainless steel and plastics offer little opportunity for secondary weed growth.
2. There is a 'confusing' overflow: eels would naturally use falling water to locate a climbing surface, but the discharge point from the weir crest is beyond the rest of the structure.
3. These structures are small and nearly always in remote locations. So there is seldom any electrical supply for a pump.
4. The angle of tilt – and therefore the head difference – can change on a daily basis. Any solution must be dynamic and able to cope without compromising the effectiveness of the penning structure.



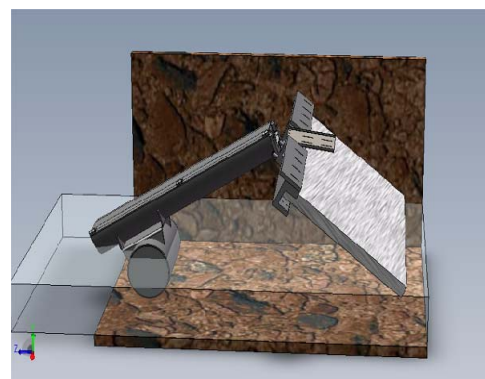
The solution is to use a gravity-fed pass, shown left with the lid open. The pass is fed water from an integral element that augments the weir crest along its width except for where the pass sits. This design encourages water to flow down the eel pass.

This self-adjusting pass is deceptively simple. There is a float at the lower end and two densities of substrate, arranged in a 'V' formation, allow for differing flow rates.

A simple gear box at its connection point to the weir crest transmits changes in the weir's angle to the upstream element. This element projects beyond the influence of the weir crest, ensuring that the eels are not swept back downstream. This upstream element has a flexible bristle substrate which continues to point down into the upstream water level at around 15° regardless of the angle of the tilting weir. The CAD illustrations below (Figures 8.3 and 8.4) show how this works: at two different penning heights and weir angles, the upstream element is maintained at a constant downwards angle via the gearbox. Also note the weir augmentation elements which force water down the pass.



**Figure 8.3: Tilting weir upright position**



**Figure 8.4: Tilting weir, lowered position**

It was essential that this pass did not affect the structural integrity of the tilting weir. To this end, no holes or fixings were drilled into the weir. Instead, the pass was clamped in place. This makes it easier to remove the eel pass at the end of the summer. The augmentation elements stay fixed to the weir crest throughout the year.

The picture below shows the same eel pass with its integral hinged lid closed. Note the level of the channel and substrate. This is maintained by the downstream float. Trial and error established the appropriate level for this size of eel pass at the range of angles at which the penning structure would operate. On this site it was found that submersion was appropriate up to the underside of the lid. A simple bag trap showed that eels started to use the pass immediately.

Weed has never blocked the pass because the upstream element sieves the weed and prevents it from entering the pass. This also has the advantage of forming a localised floating raft of weed that creates some cover for the emerging eels. Wherever possible, the pass should be made from recycled materials.

The pass can be adapted and installed on structures such as C,F,G and J.



#### **Components:**

Substrate: Bristles spaced at 20mm and 30mm on 100mm width baseboards. Also used flexible, rubber-backed substrate. The rigid substrate boards are removable from the pass and were supplied by: Cottam Brush Ltd. For more details see [www.cottambrush.com](http://www.cottambrush.com) or phone 0845 434 84 36

Channel/pass: Supplied by Berry and Escott Engineering, Bridgwater, Somerset, TA6 5LT. Phone 01278 444861. Email [info@berryengineering.co.uk](mailto:info@berryengineering.co.uk)

Installation: Berry and Escott Engineering and Environment Agency staff.

## Lessons learned

### Substrate

Practical experience has shown that laying a bristle substrate with a 20mm gap between bristle clumps alongside another with 30mm spacing will allow the passage of eels/elvers ranging in size from 80mm to 750mm. This narrower spacing is favoured by smaller eels and may therefore not be appropriate for sites higher up catchments – where larger eels may be more prevalent.

### Slope

As ramp length increases, the angle of the slope should decrease. However practical experience has shown that even with steep slopes (up to 60°) eels are still able to ascend quite long ramps. In exceptional circumstances, it may be appropriate to have steeper passes up to 75°.

### Flow

The channel element of the pass will need relatively little water to be effective. For a channel 200 mm wide and lined with bristle substrate, a flow of 0.5 litres/second will feed both the downstream element and the upstream delivery pipe.



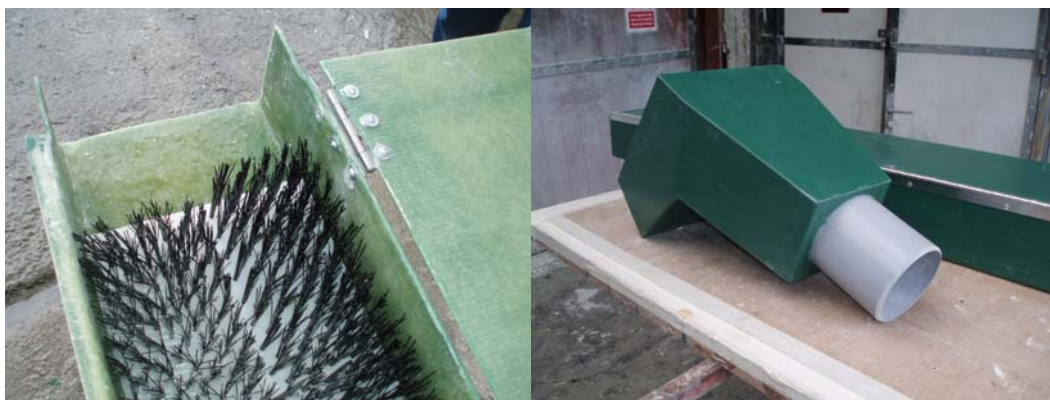
# Appendix

## Modular eel pass channel components



GRP channel in modular sections with male/female ends  
240 cm x 20 cm (internal) x 10cm

Each section has full-length hinged lid



Bristle substrate (100mm width x 2)  
Fixed with stainless steel,  
self-tapping screws

Flow-splitter for pumped passes



Channel with flow-splitter attached



Pre-formed angles make installation easier



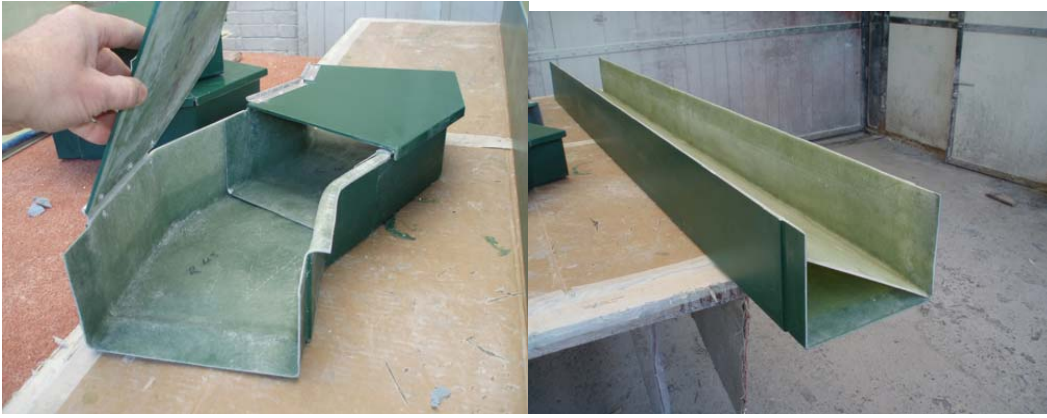
Each has own hinged lid

30° and 45° but bespoke angles can be made



Can be used in combination





Channel for gravity-fed passes



Same dimensions but with taller sides (150mm)

Sample substrate inserted. Triangular void blanked off so that all water flows ~ through substrate



Self-adjusting eel passes for tilting weirs







**S+D Plastics** of Burnham-on-Sea,  
Somerset.

Phone: 01278 781853

Email: [sdplasticsales@googlemail.com](mailto:sdplasticsales@googlemail.com)



# Glossary of terms

**Apron.** Usually made from concrete or rock-filled gabion baskets. The apron is installed upstream and downstream of the gauging structure to prevent erosion of the river bed.

**Bootlace eel.** Non-technical term used for juvenile eels in the first and second year fresh-water life stage.

**Brackets.** Flat stainless steel bar bent and drilled to allow fixing of bristle boards to the wing walls.

**Bristle boards.** Plastic boards drilled at intervals with bunches of monofilament bristles inserted into the holes. Provides a medium for eels and elvers to gain purchase and crawl upstream.

**Bristle tufts.** Bunches of monofilament strands inserted into backing boards.

**Crawling gutter.** Artificial channel filled with a crawling medium. Supplied with a water flow to allow eels to pass an obstruction.

**Crest.** The highest point on a gauging structure. Maintains the upstream water level.

**Crump weir.** Gauging structure with a horizontal crest and angular profile, The upstream slope is 1 in 2; the downstream slope is 1 in 5.

**Eel.** If you need a definition for eel, you are perhaps starting with the wrong manual. But they are a catadromous fish which migrate as juveniles from the sea to fresh water, where they spend a proportion of their life.

**Elver.** Juvenile, pigmented eel (0+), often entering fresh water in late spring and early summer. This term is only used in the UK. For the rest of Europe the term yellow eel is used for all immature pigmented eel.

**Flat V crump weir.** An angular profile weir – similar to the crump weir but with a V-shaped crest rather than a horizontal one. V crump weirs are usually found on rivers with a low summer discharge.

**Glass eel.** Juvenile, non-pigmented eel which migrate to coastal and fresh waters.

**Head differential.** The difference between the water level upstream of a structure and the water level downstream.

**Head water level.** The water level above a structure.

**Tail water level.** The water level downstream of a structure.

**Wing walls.** Vertical walls usually made from brick concrete or gabion baskets to protect banks from erosion at a gauging structure and provide a stable gauging dimension. They run parallel to the river flow.

**Yellow eel.** A pigmented eel resident in fresh or coastal waters. In the UK the term is used for >0+ eel.



# Manufacturers

The following manufacturers have products described or mentioned in this manual:

## **Aquatic Control Engineering Ltd (ACE)**

Hall Farm, Main Street, Rampton, Nottinghamshire, DN22 0HR

Phone: 01777 249080

Website: [www.aquaticcontrol.co.uk](http://www.aquaticcontrol.co.uk)

Contact: Marcus Widdison

## **Fish Flow Innovations**

vanTwickelostraat 2, PO Box 423, 7400 AK Deventer, Netherlands.

Phone: +31 570 619292.

Website: [www.fishflowinnovations.nl](http://www.fishflowinnovations.nl)

Check out product information at:

<http://www.fishflowinnovations.nl/21/index.html>

## **Fish-Pass**

8 Allée de Guelédan, ZA Parc Rocade Sud, 35135 Chantepie, France.

Phone: +33 (0)2 99 77 32 11

Website: [www.fish-pass.fr](http://www.fish-pass.fr)

Email: [fishpass@fish-pass.fr](mailto:fishpass@fish-pass.fr)

Contact: Dr Antoine Legault

Fish-Pass is a small company that undertakes research and consultancy on freshwater fisheries. It also manufactures and supplies complete systems for eel and elver passage facilities. Their products include:

- bristle substrate mats;
- plastic moulding substrates;
- pass-traps;
- prefabricated passes;
- design and fabrication of eel lifts;
- design of standard passes for eels.

## **Ham Baker**

Garner Street, Etruria, Stoke-on-Trent, ST4 7BH

Phone: 01782 202300

Website: [www.hambaker.co.uk](http://www.hambaker.co.uk)

Contact: Malcolm Sargeant

## **Juel Tide Gates**

9732 12thArea SW, Seattle, Washington 98117, USA

Phone: +1 206 300 4204

Website: [www.jueltide.com](http://www.jueltide.com)

Contact: Jeff Juel.

**LandustrieSneek BV**

PO Box 199, NL-8600 AD Sneek, Netherlands.

Phone: +31 515 486888.

Website: [www.landustrie.nl](http://www.landustrie.nl)

Contact: WabeJager.

Represented in by UK by:

Deritend Group Ltd

Cyprus Street, off Upper Villiers Street, Wolverhampton WV2 2PB.

Website: [www.deritend.co.uk](http://www.deritend.co.uk)

Contact: Jamie Wesley (mobile no: 07795 007853)

**Milieu Inc.**

188 Henrysburg, Saint-Bernard-de-Lacolle, Quebec, Canada J0J 1V0

Phone: +1 514 247 2878.

Website: <http://www.milieuinc.com/>

Email: [milieu@gig.net](mailto:milieu@gig.net)

Contact: Denis Desrochers

Milieu Inc is an environmental consultancy and supplier of the Eel-ladder substrate ramps. Their products and services include:

- eel-ladder plastic substrate ramps;
- eel-ladder elver substrate;
- design, fabrication and evaluation of eel passes.

**NijhuisPompen BV**

Parallelveg 4, 7102 DE Winterswijk, Netherlands

Phone: +31 543 547474

Website: [www.nijhuis.norit.com](http://www.nijhuis.norit.com)

**Stoneman Engineering (SW) Ltd**

Park Works, Station Road, Willand, Cullompton, Devon EX15 2QA

Website: [www.stoneman-engineering.co.uk](http://www.stoneman-engineering.co.uk)

**Tauw BV**

Handelskade 11, PO Box 133, 7400 Deventer, Netherlands

Phone: +31 570 699328

Website: [www.tauw.nl](http://www.tauw.nl)

Contact: Anne Bosma

UK partners are W S Atkins. Contact John Sheppard in their Peterborough Office on 01733 366917.

**Waterman Industries**

25500 Road 204, Exeter, California 93221, USA

Phone: +1 559 562 4000

Website: [www.watermanusa.com](http://www.watermanusa.com)

**Sotubema**

Brie Comte Robert, BP 95, 77253 Coubert Cedex, France

Phone: +33 1 64 06 76 05

Manufacture Pelcar and Evergreen concrete blocks.

**MMG Civil Engineering Systems Ltd**

Vermuyden House, Wiggshall St Germans, Kings Lynn, Norfolk PE34 3ES

Phone: 01553 85791

Website: [www.mmgces.co.uk](http://www.mmgces.co.uk)

Manufacture the Enkamat geotextile.

**American Wick Drain Corporation**

1209 Airport Road, Monro, NC 28110, USA

Phone: +1 704 238 9200

Website: [www.americanwick.com](http://www.americanwick.com)

Manufacture the Akwadrain substrate.

**Bristle substrate suppliers****Cottam Brothers Ltd**

Sheepfolds Industrial Estate, Sunderland, SR5 1BB

Phone: 0191567 1091.

Email: [info@cottambros.com](mailto:info@cottambros.com)

Website: [www.cottambros.com](http://www.cottambros.com)

**Dawson and Son Ltd**

Eldon Brush Works, Clayton Wood Rise, West Park Ring Road, Leeds, LS6 6RH.

Phone: 0113 275 9321

Website: [www.dawsonbrush.co.uk](http://www.dawsonbrush.co.uk)

**Cooks of Norwich**

9 Concorde Road, Norwich NR6 6BH

Phone: 01603 484444.

Website: [www.cooks-brushes.co.uk](http://www.cooks-brushes.co.uk)

**W S Read and Sons Ltd**

554 Green Street, London E13 9DA.

Phone: 020 8472 0825.



**Would you like to find out more about us,  
or about your environment?**

**Then call us on**

**08708 506 506\*** (Mon-Fri 8-6)

**email**

**enquiries@environment-agency.gov.uk**

**or visit our website**

**www.environment-agency.gov.uk**

**incident hotline 0800 80 70 60** (24hrs)

**floodline 0845 988 1188**

\* Approximate call costs: 8p plus 6p per minute (standard landline).  
Please note charges will vary across telephone providers



**Environment first:** This publication is printed on recycled paper.